

FLUKE®

Calibration

5322A

**Multifunction
Electrical Safety
Tester Calibrator**



Session Agenda

FLUKE®

Calibration

- 5322A Introduction
- Electrical Safety Test Requirements and Regulations
- Calibrator Workload
 - Applications, calibration method and differences with the 5320A
- Summary
- Questions



5322A Introduction

- The Fluke Calibration 5322A Multifunction Electrical Tester Calibrators, with 5 kV voltage measurement and optional 5 kV high resistance sourcing, can easily calibrate your entire electrical safety tester workload
- The workload ranges from
 - older hand-cranked insulation testers
 - current day safety testers such as
 - insulation resistance testers
 - Hipot testers
 - RCD testers
 - earth ground resistance testers
 - loop/line impedance testers
 - ground bond testers, portable
 - appliance testers (PATs)
 - multi-function testers.

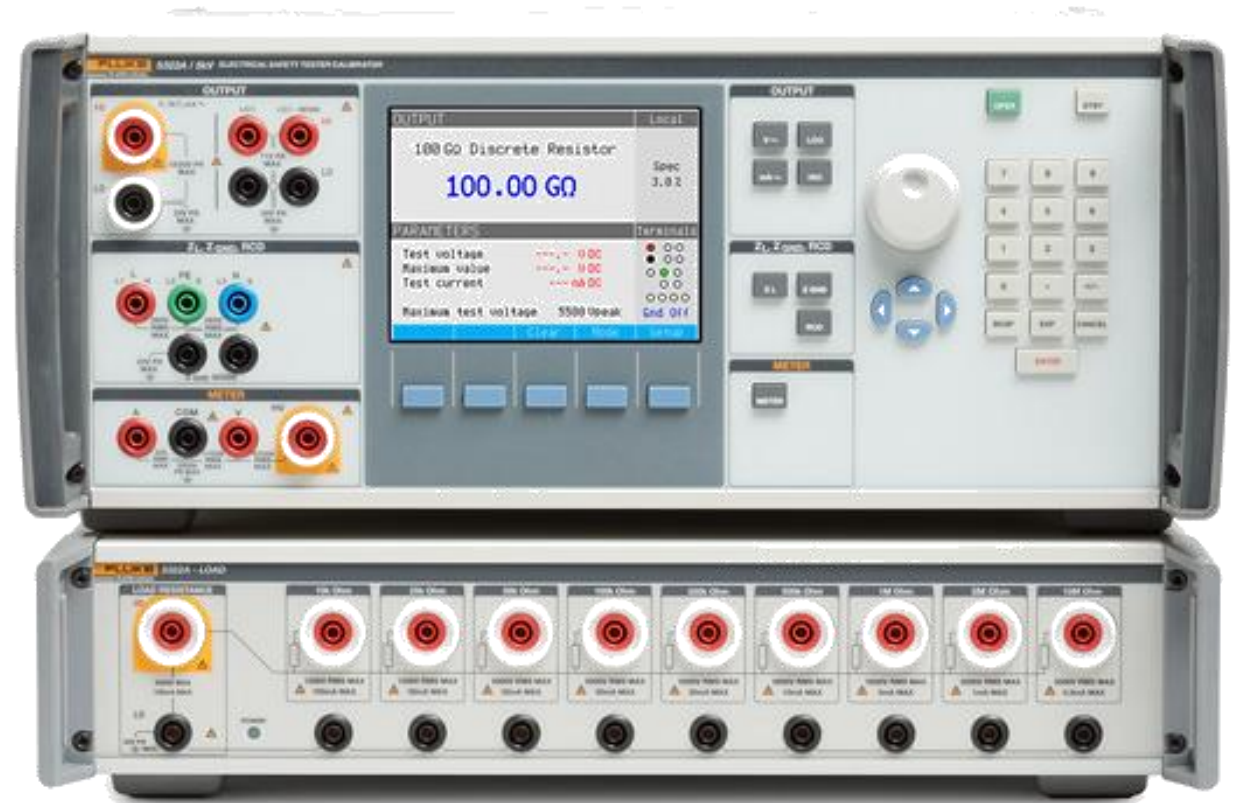

5322A Introduction

- The 5322A replaces the 5320A, with additional features and capabilities:
 - Wider and more complete workload coverage
 - More comprehensive regulatory compliance (mainly China market)
 - Improved robustness and reliability
 - Multi-language UI and built-in Help
- Easier to use individual (10 kV) R-Multiplier and HV Divider boxes



5322A Introduction

- The 5322A-LOAD accessory replaces the 5320A-LOAD
 - Higher voltage capability
 - Greater load resistance value (leakage current) choice



5322A Introduction

FLUKE®

Calibration

- Functions & Features:
 - Low Resistance Source (2, 3 & 4 wire)
 - High Resistance Source (1.5 kV standard, 5 kV optional)
 - Ground Bond Resistance Source (2 & 4 wire)
 - Line/Loop Impedance Sources
 - Leakage Current Source
 - RCD (RCD, MFT & PAT tester compatible)
 - AC/DC Voltage Calibrator (VLC option only)
 - Multimeter (also provides HiPot Voltage, Leakage/Trip & Timer and PAT Flash)

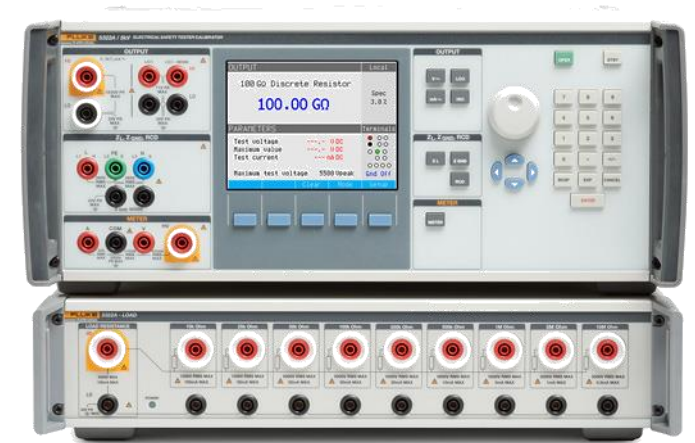

Electrical Safety Testing Regulations



IMPORTANT

This installation should be periodically inspected and tested and a report on its condition obtained as prescribed in the IET Wiring Regulations BS7671 Requirements for Electrical Installations.

Date of Last Inspection:.....
Recommended Date of
Next Inspection:.....

CONTACT DETAILS
Printed across here - NO LOGO's
Maximum 3 lines

ELECTRICAL SAFETY TEST

APP. I.D. **FAILED** BY

TEST DATE **DO NOT USE**

ELECTRICAL SAFETY TEST

DATE / INITIALS

APPL. / REF NO.

NEXT TEST DATE

PASSED

Labels Online.co.uk

Electrical Safety Testing Requirements

- Manufacturers of electrical products cannot prevent consumers from improperly using their products or from defeating safety ground systems. They only can warn them of the risks. On the other hand, products with faulty insulation must not leave a manufacturing or repair facility.
- However, if products meet agency requirements for electrical safety tests, you have met your obligation as a responsible supplier by doing everything in your power to ensure that your products are electrically safe.
- International safety testing agencies such as the Underwriters Laboratories (UL), the Canadian Standards Association, the Association of German Electrical Engineers (VDE) and (TüV), and the International Electrotechnical Commission (IEC) specify dozens of safety tests for electrically operated products.



Electrical Safety Testing Regulations

- What are the regulations?
 - Ensuring the electrical safety of licensed electrical workers, other workers, licensed electrical contractors, consumers and the general public;
 - Enhancing consumer protection in relation to electrical work;
 - Ensuring a safe supply of electricity;
 - Ensuring electrical equipment hired or sold is electrically safe.

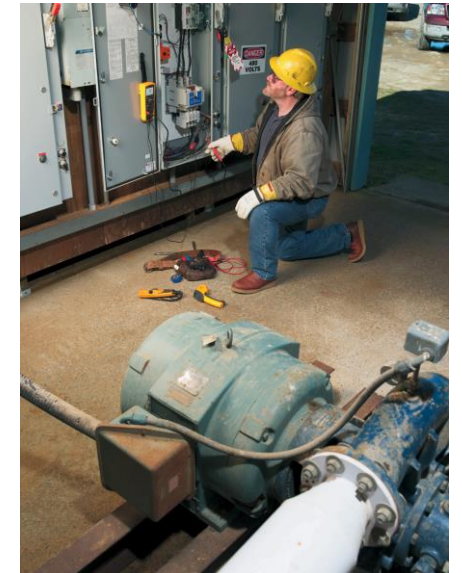

5322A Workload

FLUKE®

Calibration



5322A Workload

FLUKE®

Calibration

- Installation testers
- PAT testers
- Electrical safety testers
 - High voltage testers (HIPOT)
 - Insulation resistance testers
 - Ground bond testers
 - Leakage current testers
- Insulation resistance testers (portables also known as Megohm meters or Meggers)
- Earth resistance testers
- RCD testers



Installation Testers

- Safety testing for installations is mandated by local regulations in Europe, Australia, and parts of Asia
- Annual testing must be made on installations (buildings) to meet safety regulations
- IEC60364 drives local standards like EN 61557 in the UK and VDE 0100 in Germany
- The testers range from single-function to multi-function.
- Tester Functions
 - Loop/line impedance testers
 - RCD testers (similar to GFCI)
 - Continuity testers
 - Insulation resistance testers
 - Earth resistance testers



Portable Appliance Testers (PATs)

- Safety testing for appliances and devices (like fridges, washing machines and lamps) is mandated by local regulations in Europe, Australia and parts of Asia
- Annual safety tests are required for appliances in public or work areas as determined by the local regulation.
- In the UK standards like EN 60601/60335/60950/ 61010 and VDE 0700/0701/0702/0751 in Germany drive certain tests.
- Tester functions
 - Leakage current tests (substitute, contact/direct)
 - Ground bond tests
 - Appliance power and load current tests
 - Insulation resistance tests
 - Portable RCD Trip time tests



A calibrator for the future

FLUKE®

Calibration

- Functions & Features:
 - Low Resistance Source (2 & 4 wire)
 - High Resistance Source (1.5kV standard, 5kV optional)
 - Ground Bond Resistance Source (2 & 4 wire)
 - Line/Loop Impedance Sources
 - Leakage Current Source
 - RCD (RCD, MFT & PAT tester compatible)
 - AC/DC Voltage Calibrator (VLC option only)
 - Multimeter 1 kV and 5 kV (also provides HiPot Voltage, Leakage/Trip & Timer and PAT Flash)



A calibrator for the future

- Large color display
 - Large numeric readouts that are color coded
 - Blue for sourced values, red for measured values and black for reference values
 - Look at the active terminal window to know which terminals should be used for a set function

The image shows a screenshot of a Fluke calibrator's color display. The display is divided into several sections:

- OUTPUT**: Shows "High Resistance Source" and a large blue value "100.25 MΩ" with a red lightning bolt icon to its left. To the right, it shows "Local" and "Spec 1.0%".
- PARAMETERS**: Lists test parameters: "Test voltage 105 V DC", "Maximum value 105 V DC", "R multiplier No", and "Maximum test voltage 1575 Vpeak".
- Terminals**: Shows a grid of terminal indicators with colored dots (red, black, green) and circles.
- Softkeys**: A row of four blue buttons at the bottom: "R Mult.", "Clear", "Mode", and "Setup".

Annotations with arrows point to these features:

- "Blue Value = Sourced" points to the "100.25 MΩ" value.
- "Red Value = Measured" points to the red lightning bolt icon.
- "Black Value = Reference" points to the "105 V DC" values.
- "Softkeys" points to the bottom row of buttons.
- "Spec of the sourced value" points to "Spec 1.0%".
- "Active Terminal Window (5320A layout)" points to the terminal indicator grid.

A calibrator for the future

- Built-in calibration graphical help guide
 - Every function has a graphical help guide that can be accessed from the front panel in the event extra help is needed.

High R Pg. 1/8

In high resistance mode the calibrator sources high resistance values for both AC and DC high voltage applications. It can be used for calibration of insulation resistance testers, megohm meters and other testers with insulation resistance testing capability.

Connect UUT as follows:

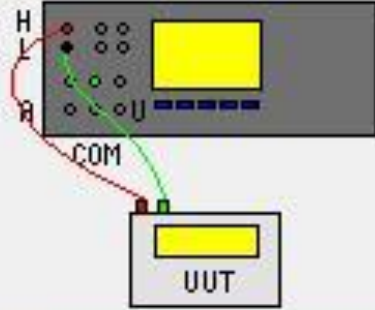

Next Exit

A calibrator for the future

- Selection of communication interfaces
 - USB and GPIB are all standard
 - Upgrade instrument firmware in your lab over USB



5322A Test Applications

FLUKE®

Calibration

- Insulation resistance
- Earth resistance and continuity
- Loop and line impedance
- Residual Current Device
- Ground bond
- Leakage current
- High voltage breakdown
- PAT load test

Electrical Safety

ELECTRICITY CAN KILL

- + Each year about 1000 accidents at work involving electrical shocks or burns are reported to Health & Safety Executive.
- + Around 20 of these are fatal.
- + Shocks from voltages over 50 volts AC or 120 volts DC are hazardous.
- + Even non-fatal shocks can cause severe and permanent injury.



ASSESSING THE RISKS

Health and safety risk assessment should take into account the risks associated with electricity.

Risk assessment consists of 5 steps:

01. Identifying the hazards.
02. Deciding who might be harmed and how.
03. Evaluating the risks and deciding on precautions.
04. Recording your findings and implementing them.
05. Reviewing your risk assessment and updating it if necessary.

Most common risks come from:

- + Contact with live parts.
- + Electrical faults and the risks are greatest where the equipment contains a heat source.
- + Flammable or explosive atmospheres.
- + Harsh conditions where unsuitable equipment can easily become live and can make its surroundings live and dangerous.
- + Confined spaces where if an electrical fault develops it will be very difficult to avoid a shock.
- + Some of the equipment such as extension leads and flexible leads which are particularly liable to damage.

For further guidance please see HSE's website (www.hse.gov.uk/hsk/)



REDUCING THE RISKS FOR EMPLOYERS

Ensure people working on or with electrical equipment or systems are 'competent' for the task.

Ensure the electrical installation:

- + Complies to BS 7671 Requirements for electrical installations.
- + Is maintained in a safe condition.
- + There are enough socket outlets are provided.

Provide safe and suitable equipment:

- + Equipment must be suitable for its working environment.
- + Consider using air, hydraulic or hand-powered tools in harsh conditions.
- + Provide a switch near each fixed machine to cut off power in an emergency.
- + Replace damaged sections of cable completely.
- + Special electrical equipment should be used in potentially flammable or explosive atmospheres.
- + Consider asking for specialist advice.

Reduce the voltage:

- + Temporary lighting can be run at lower voltages.
- + Battery-operated tools are safest.
- + Portable tools designed to be run from a 110 volt centre-tapped-to-earth supply are available.

Provide a safety device (an RCD) if equipment operating at 230 volts or higher is used. An RCD is a device which detects some faults in the electrical system and rapidly switches off the supply.



WHAT DO THE REGULATIONS REQUIRE?

The Health and safety at Work Act 1974 states that:

- + Employers are responsible for ensuring the safety and health of their employees and the public, if they are at risk from work activities.

The Electricity at Work Regulations 1989 states that:

- + Electrical systems must be constructed in a way that prevents danger.
- + Employers, employees and the self-employed must maintain the electrical systems as necessary to prevent danger.
- + Employers, employees and the self-employed must work on, use of electrical systems carried out in a way that prevents danger.
- + Electrical equipment used in hazardous environments must be constructed or protected to prevent it becoming dangerous.
- + Only those with competent knowledge or experience or under adequate supervision should work with, or on, electrical equipment that could cause danger or injury.

The Reporting of Injuries, Diseases and Dangerous Occurrences Regulations 1995 states that:

- + The enforcing authority must be notified immediately by telephone using the Incident Reporting Line 0845 300 9923 or via the Health and Safety Executive's Incident Report page.



REDUCING THE RISKS FOR EMPLOYEES

Visual inspection should also be done by employees.

Work safety

- + Suspect or faulty equipment must be taken out of use, labeled 'DO NOT USE' and kept secure until examined by a competent person.
- + If possible, tools and power socket outlets should be switched off before plugging in or unplugging.
- + Equipment should be switched off and/or unplugged before cleaning or making adjustments.

Always expect cables will be present and live when digging in the street, pavement or near buildings.

Have overhead electric lines switched off if possible or maintain safe working distance from the lines.

The line or track operating company must be consulted before starting work near electrified railways or tramways.



© Safety First Aid Group Ltd 2013

The information contained in the poster is for guidance only and should not be used as a substitute for recognised training.

A623(V1)

Insulation Resistance

FLUKE®

Calibration



Insulation Resistance

FLUKE®

Calibration

- Megohm meters measure the insulation resistance of devices and installations.
- For example insulation resistance tests are made on:
 - Building wiring
 - Motors
 - Cables
 - Switch gear
- Applications include:
 - Ensuring wiring and electrical devices meet codes and standards
 - Predictive maintenance testing



Insulation Resistance Tester – Theory of Operation

- The Megohm meter supplies a test voltage to the device under test.
- The meter measures the leakage current (through a known shunt resistor) and calculates the resistance.
 - $R = V/I$
- *That is why you NEVER shall use a Megohm meter on a normal Multifunction Calibrator like the 5502A or 5522A!!*
 - *A normal DMM supplies a (small) current and measures the voltage across the resistor*
- Portable Megohm can supply DC voltages in the range of 50 V to 5000 V

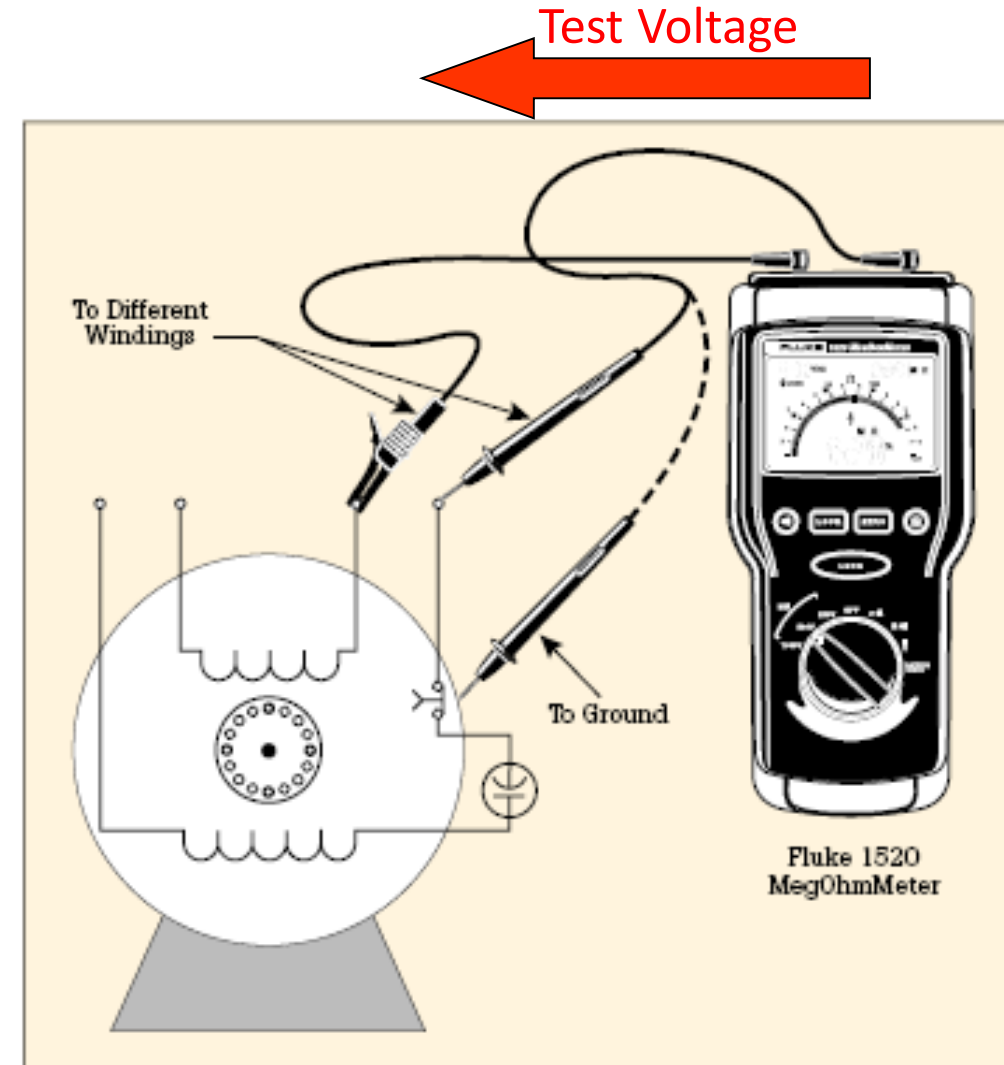

Insulation Resistance - Application example - cable Test

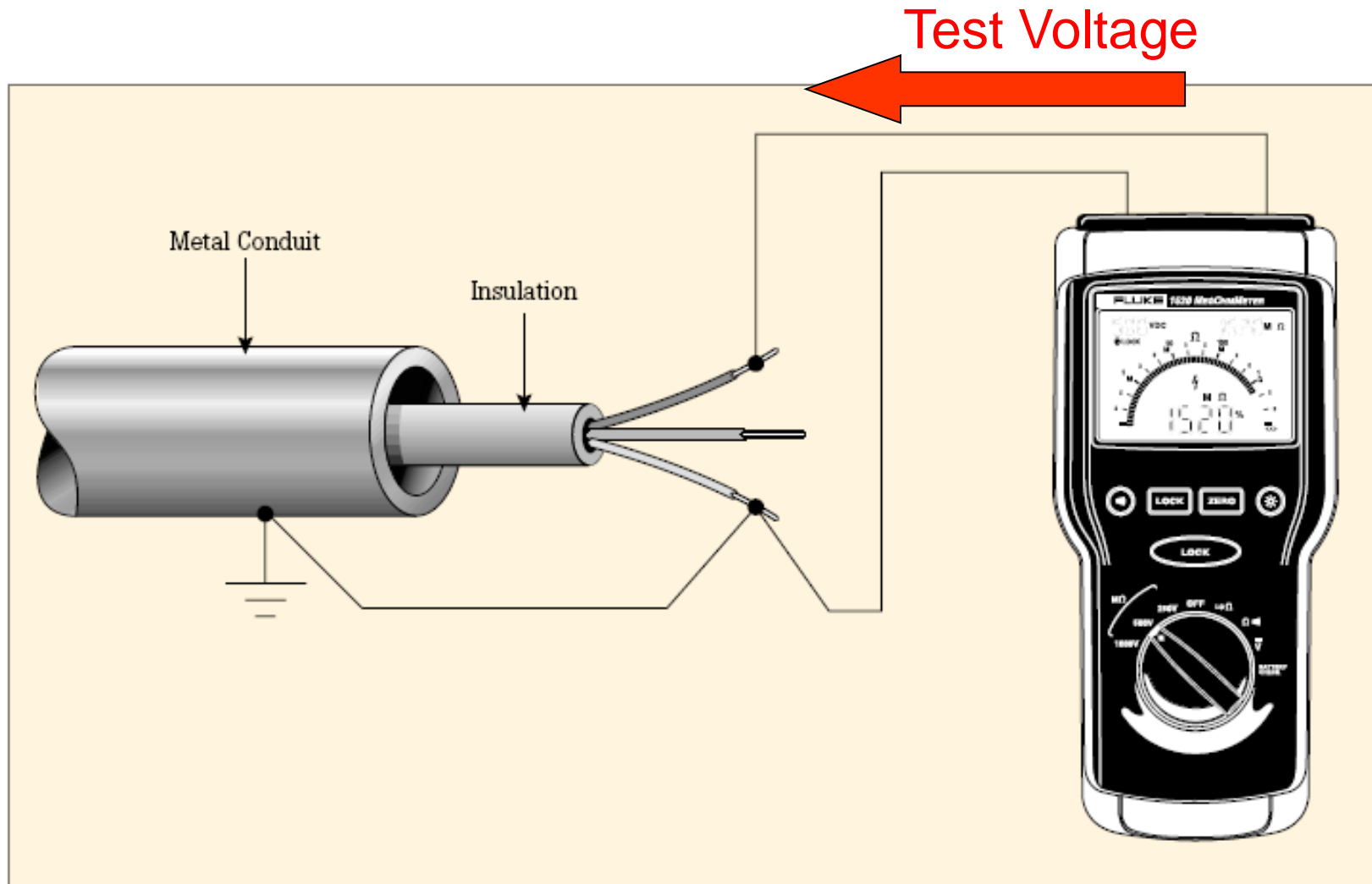

Insulation Resistance Tester Types

- Handheld/Portable



- Benchtop (Electrical Safety)



Calibrating Insulation Testers

- Optional choice of existing 1.5 kV (5322A) or new 5 kV High Voltage Resistance (5322A-5) version
- Using the “High Ohms” function, the 5322A sources real resistors, 4½ digits of resolution
 - 10 kΩ to 10 GΩ continuously variable, 100 GΩ fixed (1.5 kV Version, just as the 5320A)
 - 10 kΩ to 100 GΩ continuously variable (5 kV Version)
 - To 10 TΩ (using the external 1000x resistance multiplier, up to 10 kV)
- During calibration the 5322A simultaneously measures the test voltage and calculates the current from the insulation tester
 - To 1575 V_{peak} (1.5 kV version)
 - To 5500 V_{peak} (5 kV version)

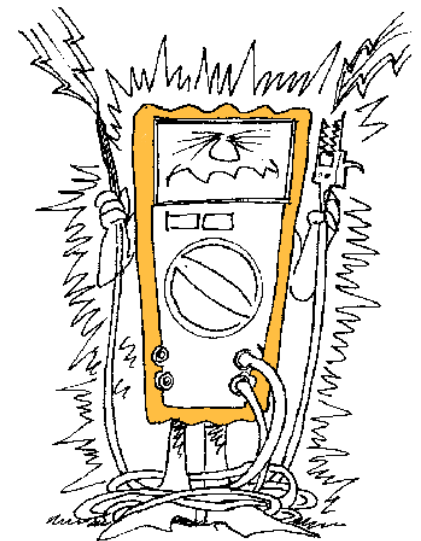

Calibrating Insulation Testers – Additional functionality 5322A



- Additional workload with 5322A-5
 - Calibration of 2 & 3 terminal insulation testers and hand-cranked "meggers" up to 5 kV.
 - Solves problem that 2-terminal >1.5 kV testers could not be calibrated using the HV Divider/ R-Multiplier box accessory.
 - Solves the China market problem that hand-cranked "meggers" (typically 2.5 kV) are not compatible with the HV Divider/R-Multiplier accessory.
- High Voltage Resistance Source hot-switching to 3 kV
 - Continuous resistance value adjustment (slewing) with the output energized.
 - For analog "megger" calibration, allowing UUTs to be set to read specific scale values.

Earth Resistance Testing

FLUKE®

Calibration



Earth Resistance Testing

- Installations are grounded to earth for two primary reasons
 - Stabilize the voltage to earth during normal operation
 - Limit the voltage rise from lightning or line surges
- Earth resistance testers check the adequacy of the grounding for installations
- The International Electrical Testing Association specifies ground electrode testing every three years



Earth Resistance Testing - Applications

- Grounding systems include:
 - Power generating stations
 - Electrical-distribution systems
 - Industrial plants
 - Telecommunication systems
 - Lightning arrester installations
- Applications include:
 - Ensuring wiring meets codes and standards
 - Predictive maintenance testing



Earth Resistance Testing - Theory of Operation

- Earth resistance testers use poles staked around the grounding system to determine the resistivity of the soil
- Rod 1 is staked near the ground rod of the installation
- Rod 3 is typically staked 15 to 20 meters from Rod 1

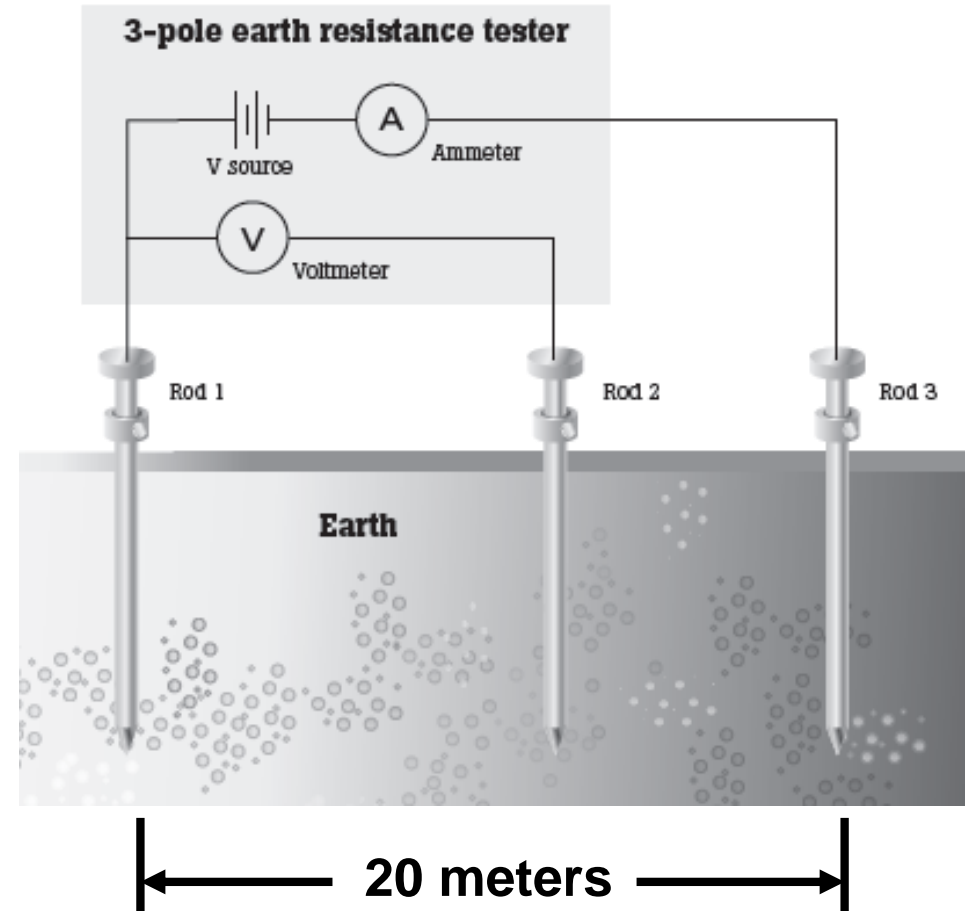

Earth Resistance Testing - Theory of Operation

- A known current flows from rod 3 to rod 1
- The resulting voltage is measured at various points between rod 1 and 2
- Earth resistance is plotted by moving Rod 2
- The 62% region should be flat (the distance from rod 3 to 1)

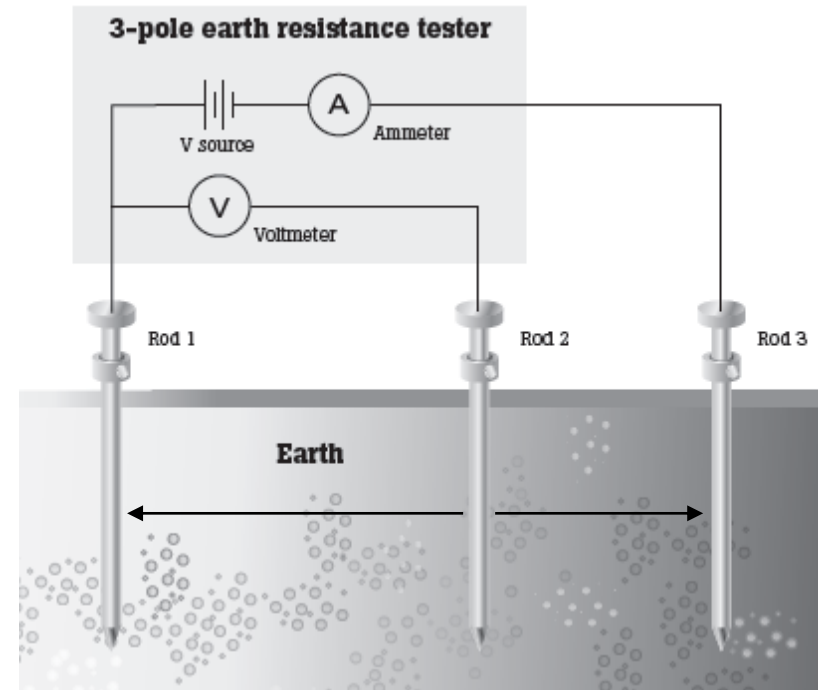
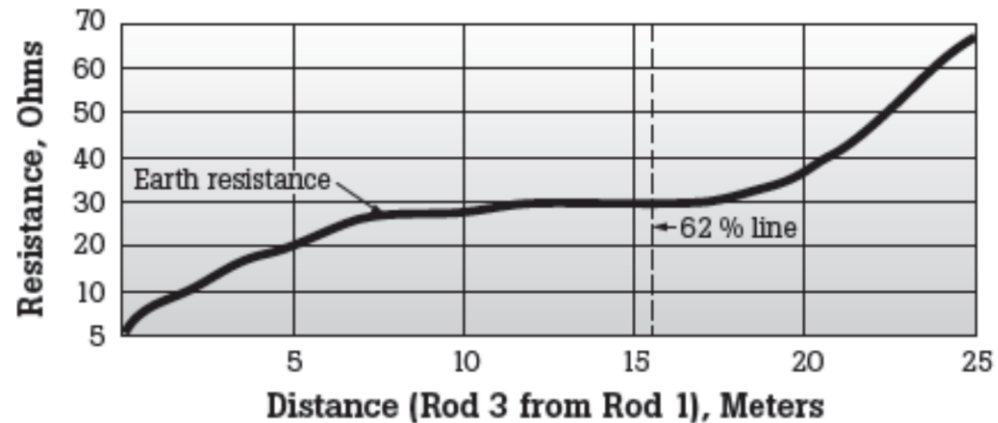

Earth Resistance Tester Types

FLUKE®

Calibration

- Handheld/Portable



Calibrating Earth Resistance Testers

- Using the “Lo Ohms” function, the 5322A sources real resistors, 3½ digits of resolution
 - 10 mΩ fixed value
 - 100 mΩ to 10 kΩ
 - 2-, 3- or 4-wire
- During calibration the 5322A simultaneously measures the test current from the earth tester
 - Up to 700 mA (1000 mA for the 10 mΩ fixed value)
 - Check the “Maximum Test Current” value on the display, it differs per selected Ω-value
 - The calibrator will trip to standby if the maximum is exceeded.



5322A Additional Workload

- 10 mΩ fixed calibrated value
 - Address China earth resistance tester calibration regulations requirement for <100 mΩ measurements and for lead resistance sensitivity testing
- Low Voltage Resistance max current increased from 400 mA to 700 mA (1000 mA)
 - Improved robustness
- Improved Low Voltage Resistance test current measurement for low resistance values at 200mA
 - Improved TARs eliminating indeterminate or false fails/accepts when verifying MFT & continuity tester UUTs against EN61557 requirements.

Loop and Line Impedance

FLUKE®

Calibration

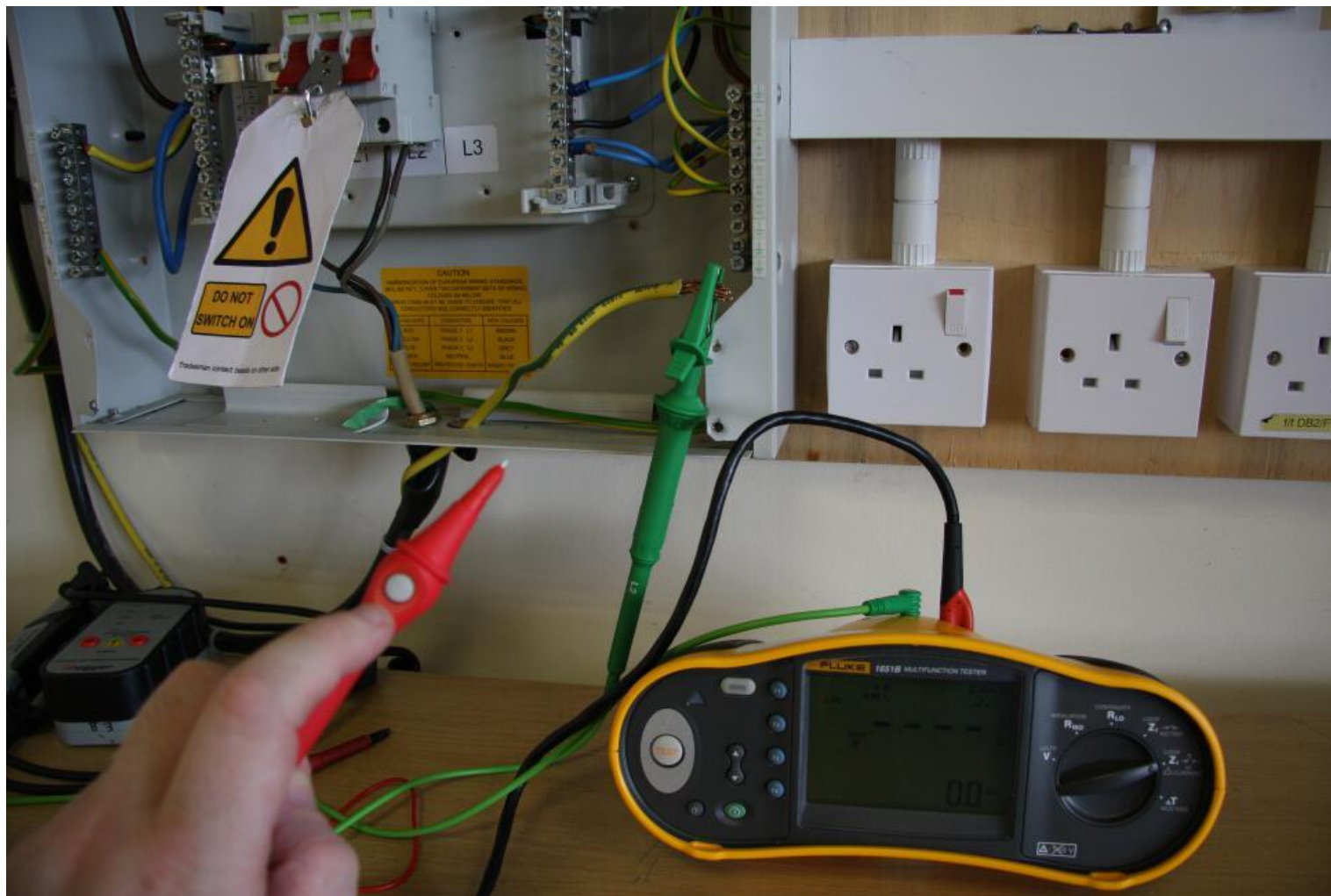

Loop and Line impedance

- Loop testing demystified
 - Of all the tests that contractors routinely perform on electrical installations, earth loop impedance testing creates the most confusion and uncertainty.
 - Why is the test needed and which test method is it best to use?
 - If a fault occurs in an electrical installation, sufficient current will flow to operate the fuse or circuit breaker protecting the faulty circuit within a predetermined time.
 - The objective is to make sure that the circuit is disconnected fast enough to prevent overheating and possibly a fire.
- Loop impedance is measured between L and PE (LooP)
- Line impedance is measured between L and N (LiNe)

Loop and Line impedance testing

FLUKE®

Calibration

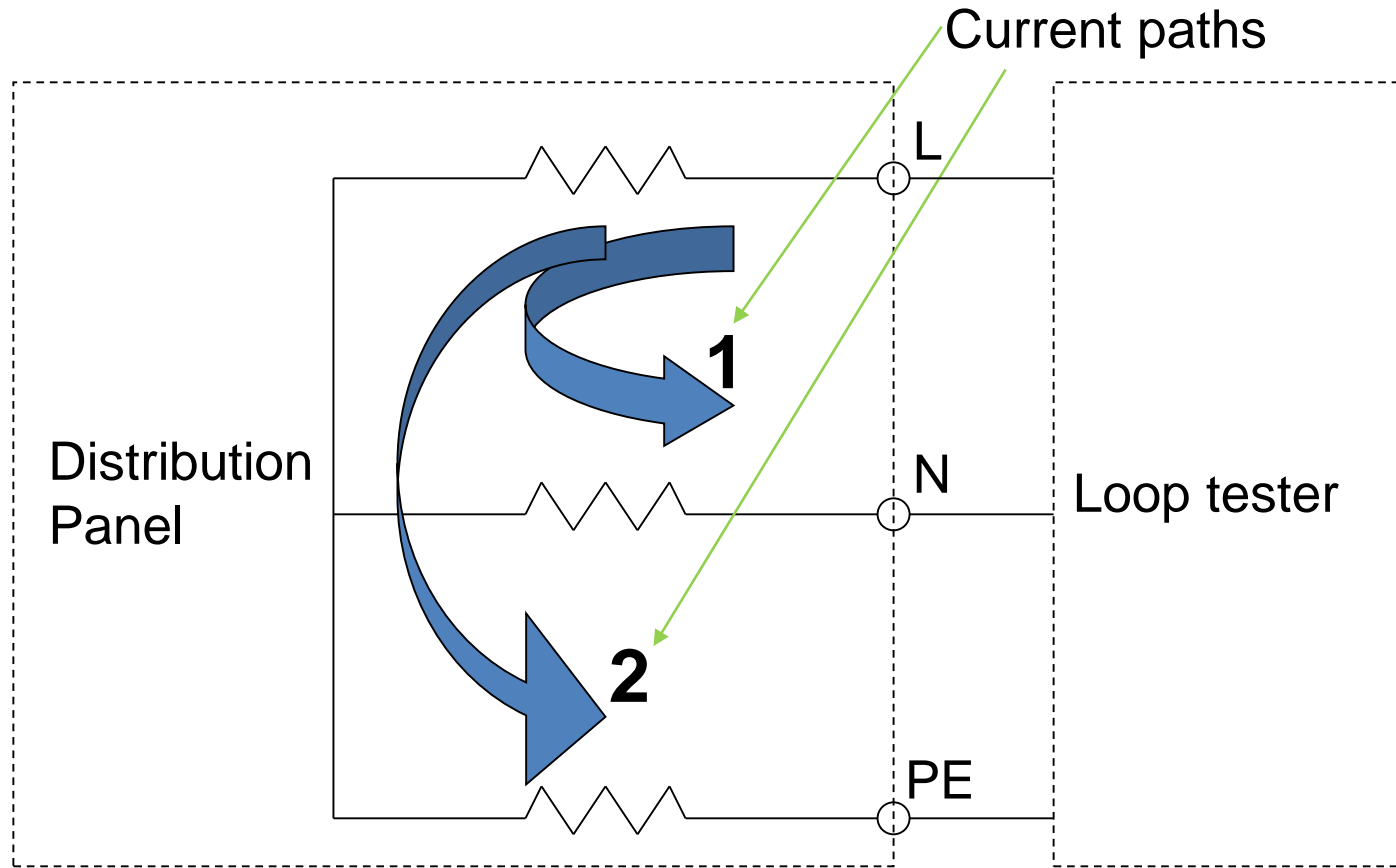

Loop testers measure the impedance of a path through

- 1. Line and Neutral (line impedance)**
- 2. Line and Protective Earth (loop impedance)**

Loop and Line Impedance testing

- A Loop tester shortly takes a relatively high current from a wall socket and measures the voltage drop
- The impedance is then calculated with $R = \Delta V / I_{\text{test}}$
- It also calculates the Prospective Fault Current (PFC) or Prospective Shortcircuit Current (PSC) with $I_{\text{sc}} = V_{\text{nom}} / R$
- This R should be low enough to trip the circuit breaker or fuse as fast as possible to prevent heat



Loop and Line Impedance

- An example of what can go wrong when a connection is not tightened and the contact resistance is high enough to cause heat in the connection

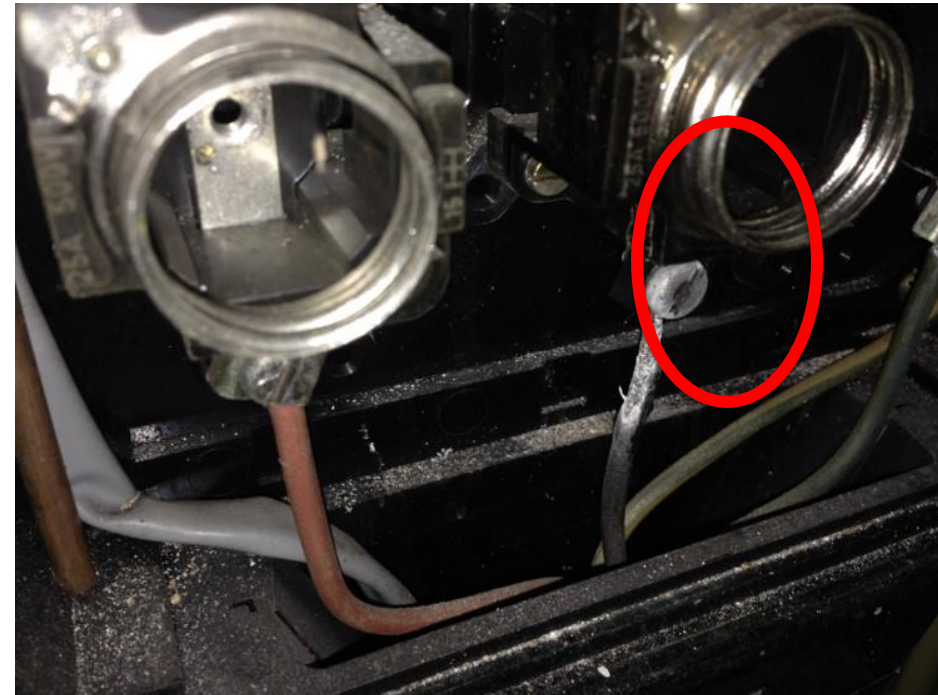

Loop and Line Impedance Testers

FLUKE®

Calibration

- Handheld / Portable



Fluke 1653



Calibrating Loop and Line Impedance Testers

- Using the “Loop impedance” function (Z_L), the 5322A sources discrete resistors
 - 16 discrete values
 - 20 m Ω to 1700 Ω
- During calibration the 5322A places the known resistor value in series with the loop or line, either in the N or PE path

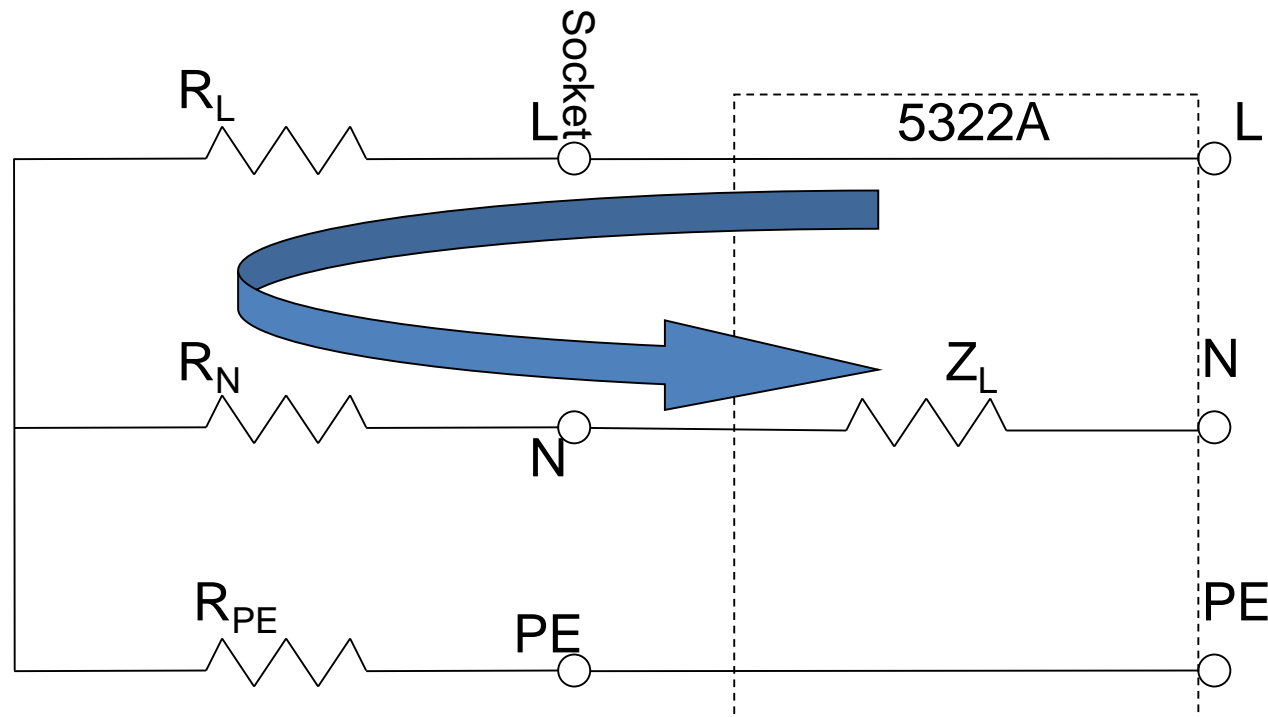

$$\text{Line impedance} = R_L + R_N + Z_L$$

$$\text{Loop impedance} = R_L + R_{PE} + Z_L$$

(where Z_L is placed in series in the PE path)

Calibrating Loop and Line Impedance Testers

- For Loop tester calibration, the loop tester measures the impedance of the total line or loop in one of the four methods provided by the calibrator to account for that impedance:

Mode	Calibrator displayed value	Loop tester displayed value
OFF	Z_L	Z_L + loop tester measured residual impedance
MAN	Z_L + user defined residual impedance	Z_L + loop tester measured residual impedance
SCAN	Z_L + 5322A measured residual impedance	Z_L + loop tester measured residual impedance
COMP (VLC only)	Z_L	Z_L + loop tester measured residual impedance + 5322A negative resistance

Calibrating Loop and Line Impedance Testers



- Residual Impedance Correction, COMP mode (VLC option only!)
- Advantages of COMP (compensation) mode for correction of residual impedance
 - COMP mode allows calibration values below the value of the residual impedance of the path (L to N, or L to PE).
 - All other modes can only use calibration values above the residual impedance
 - No math calculation is required of adding or subtracting residual impedance values
 - Limited test current of <math><25\text{ A}</math>, depending on the time of the test current
 - for details see graph in specifications

New functionality 5322A for Loop and Line impedance calibrations



- New automated reminder/message for user-initiated built-in relay cleaning.
 - Relay cleaning is required every 2 months for specification validity, and to avoid potential contact resistance changes degrading GBR 2-wire low value performance during normal usage or causing marginal 'as found' out-of-tolerance failures at routine recalibration.
 - When the 2 month period elapses, users are notified on power-up or selection of a function that uses the GBR decade (Z_L & Z_{GND}) to either initiate or bypass the built-in cleaning sequence.
 - Note: the relay cleaning process is available at any time from the SETUP menu.

New functionality 5322A for Loop and Line impedance calibrations



- Maintain output On when Z_L resistance value changed
 - Avoid 5320A usability issue of mains powered UUTs resetting and losing displayed measurement value if operator changes Z_L output value and the calibrator output switches to STBY.
- Improved Line/Loop Scan Function (Z_L) performance and usability.
 - Calibrator mains supply line/loop SCAN measurement current doubled, improving the stability and repeatability of the SCAN line and loop resistance readings
- Improved robustness and reliability.



RCD Testers



RCD Tester Calibration

- What is an RCD?
 - An RCD is a circuit breaker in installations
 - Detects fault currents flowing to earth too small to trip over-current protection devices (fuses)
 - Also portable RCD's for individual extension leads, power tools, etc.
- Why verify RCDs?
 - Critical for safety purposes
 - Testing is covered in IEC 60364 and various national equivalent standards

RCD Tester Calibration

- How does an RCD work?
 - The current balance is measured between two conductors using a differential transformer
 - A balance fault results in opening the device's contacts
 - Generally the sum of the "line" and "neutral" must equal zero
 - Otherwise there is a leakage current to somewhere else (i.e. ground)

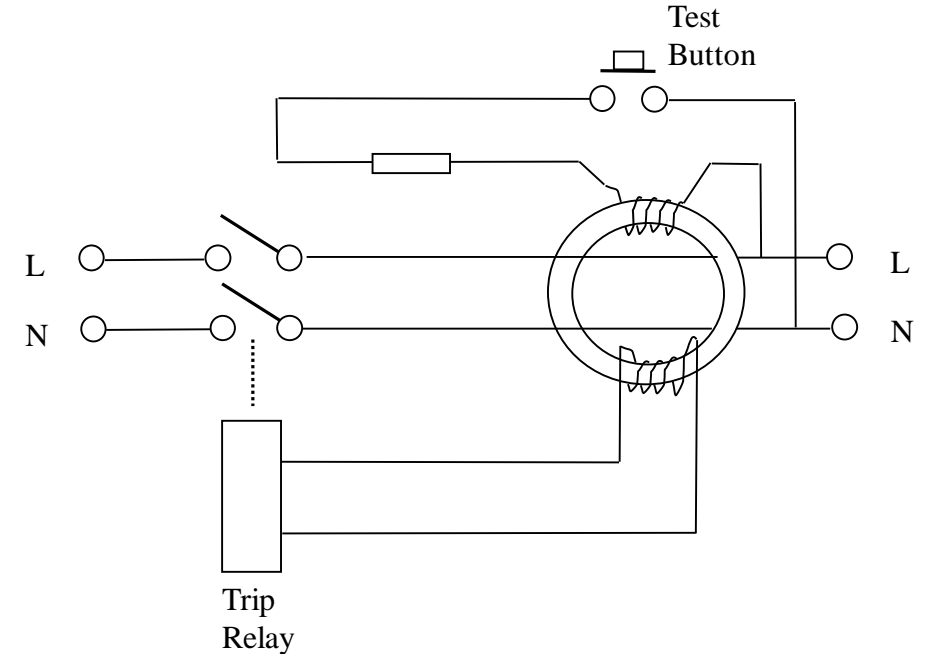

RCD Tester Calibration

- How does an RCD Tester work?
 - A calibrated fault current is induced in the circuit causing the RCD to trip
 - The RCD tester displays the time to trip plus the current trip level
 - The test can be performed at the distribution panels or at the socket outlets
- The calibrator must verify the trip time and trip current functionality of the RCD testers



Fluke 1653



RCD Tester Calibration

- Using the “RCD” function, the 5322A simulates the perfect RCD with a calibrated timer and current meter
 - RCD trip current range
 - 3 mA to 3 A
 - RCD trip time range
 - 10 ms to 5 s
- During calibration the 5322A also measures the waveform type
 - Positive and positive pulse
 - Negative and negative pulse

RCD Tester Calibration – New functionality 5322A

- New PAT RCD mode employing differential L-N UUT test (trip) current detection
 - Overcomes the 5320A RCD function incompatibility with PAT tester RCD test stimulus current generation topologies used by some models that otherwise prevents correct calibrator tripping
 - For example, the Fluke model 6500-2 PAT
 - Difference is that in this test the PAT tester is supplying the voltage and not the calibrator



RCD Tester Calibration – New functionality 5322A

- New RCD function user-selectable output on auto-reconnection after tripping.
 - The calibrator output reverts to OPER 2 seconds after entering STBY (tripping), reconnecting power to the UUT and readying the calibrator to detect a subsequent trip stimulus current event from the UUT.
 - Simplifies calibration of UUTs with only auto-sequenced RCD tests that otherwise require repeated rapid user-interventions (i.e. UUTs without individual test current/phase selections, including some PAT testers with RCD functions).
 - Improved usability with older mains powered RCD tester UUTs with limited display retention times, that may still be present in the workload.



RCD Tester Calibration – New functionality 5322A

- New supply voltage compensation for RCD function trip current measurement.
 - Automatically normalises the measurement results for the actual line voltage, for a range of user-selectable nominal line voltage settings.
 - Prevents false OOT indication with 'simpler' tester models specified at 'nominal' mains voltage having supply-dependent stimulus current.

Ground Bond

FLUKE®

Calibration



Ground Bond Test

- The ground bond test (also called PE resistance test, ground continuity test), is the first test required by the electrical safety testing standards.
- The ground bond test consists in testing whether the ground points of a device under test are well connected in between each other, and also to the mains ground.
- The measure result of a ground bond test is a resistance value, which has to be lower than the indicated limit from the international standards.
- Measurements are taken with relatively high currents
 - Typically 1 – 30 A or even 40 A

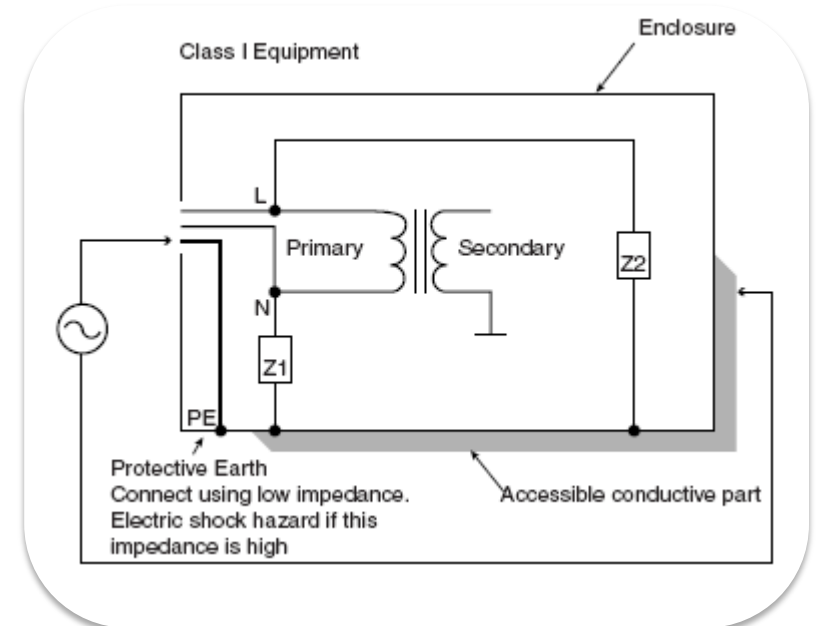

Ground Bond Test

FLUKE®

Calibration

- Making a ground bond test
 - Apply relatively high current with a low voltage.
 - Measure the voltage drop between the PE power line ground connection and the part to be earthed
 - Calculate the resistance $R = V / I_{\text{test}}$

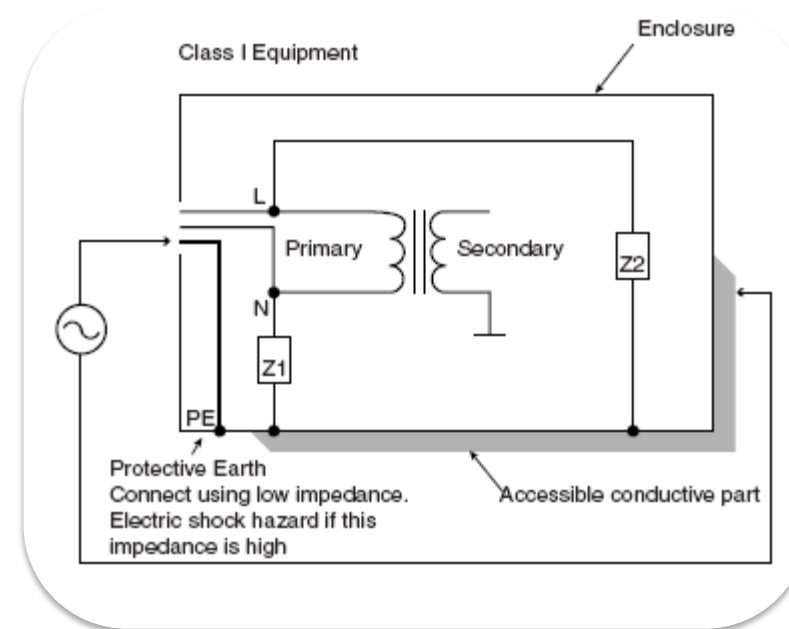

Ground Bond Tester Calibration

- The tester expects a calibrated Low Ohm value which it can measure with a relatively high current
 - Currents can go up to 30 A or 40 A
 - Therefore the Low Resistance Function of the calibrator can not be used
- Using the “ Z_{GND} ” function, the 5322A places high current rated resistors between the N and PE terminals
 - 2 Wire: 20 m Ω – 1700 Ω
 - 4 Wire: 1 m Ω – 1700 Ω
- During calibration the 5322A also measures the test current from the UUT
 - Maximum continuous test current: 30 A
 - Maximum short-term test current: 40 A

Ground Bond Tester Calibration – New Functionalities

5322A



- New 4-wire connection for Ground Bond Resistance (GBR Z_{GND}) Source, with additional front panel terminals.



- Extended range for PAT, Ground Bond and Earth resistance tester UUTs.
 - Extension of GBR (Z_{GND}) resistance range with additional <math><25\text{ m}\Omega</math> fixed values,

Ground Bond Tester Calibration – New Functionalities

5322A



- Improved correlation to Fluke 165X and 166X MFT ranges and test points.
 - 2-W: 20 mΩ, 50 mΩ, 100 mΩ, 350 mΩ, 500mΩ
 - 4-W: 1 mΩ, 14 mΩ, 39 mΩ, 94 mΩ, 340 mΩ, 490 mΩ
 - 2-W & 4-W: 960 mΩ, 1.7 Ω, 4.7 Ω, 9 Ω, 17 Ω, 47 Ω, 90 Ω, 170 Ω, 470 Ω, 900Ω, 1700 Ω
- Extra digit of resolution and additional low current range for GBR (Z_{GND}) test current measurement
 - Extra resolution at high current (30 A) for Fluke 6500 PAT tester Earth Bond test (EBT) function stimulus current measurement.
 - Lo Current mode for Earth/Ground testers with resistance ranges up to 2 kΩ.
- On-screen temperature status indicator
 - Warns user of impending overtemperature of GBR resistors before calibrator prevents further GBR function usage until temperature returns to acceptable value.

Ground Bond Tester Calibration – New Functionalities

5322A



- New automated reminder/message for user-initiated built-in relay cleaning.
 - Relay cleaning is required every 2 months for specification validity, and to avoid potential contact resistance changes degrading GBR 2-wire low value performance during normal usage or causing marginal 'as found' out-of-tolerance failures at routine recalibration.
 - When the 2 month period elapses, users are notified on power-up or selection of a function that uses the GBR decade (Z_L & Z_{GND}) to either initiate or bypass the built-in cleaning sequence.
 - Note: the relay cleaning process is available at any time from the SETUP menu.

Leakage Current

FLUKE®

Calibration



Leakage Current

- If any conductor is raised to a potential above that of earth, some current is bound to flow from that conductor to earth.
- This is true even of conductors that are well insulated from earth, since there is no such thing as perfect insulation or infinite impedance.
- The amount of current that flows depends on:
 - the voltage on the conductor.
 - the capacitive reactance between the conductor and earth.
 - the resistance between the conductor and earth.
- The currents that flow from or between conductors that are insulated from earth and from each other are called leakage currents, and are normally small.

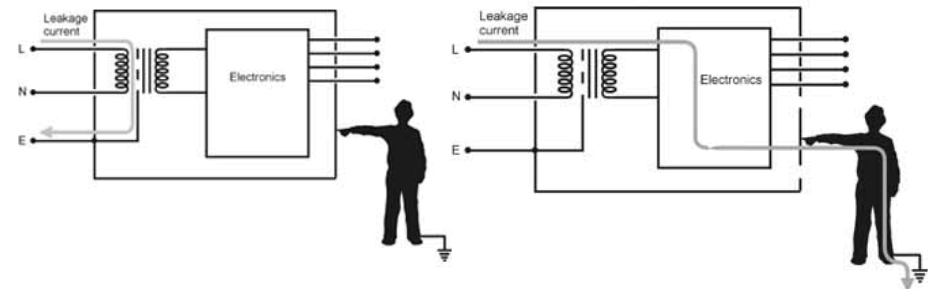

Leakage Current Tests

- The leakage current tester is a basic current meter to measure the current flow differences.
- The measurement device will also load the source of the leakage current with an impedance of 1000 to 2000 Ω (human body model). *Only In the case of touch and substitute methods*
- The tester supplies the mains voltage and measures the current
- In case the tester can not supply the voltage an external voltage source has to be used
- Normally line voltage is used except for substitute mode where a low voltage is used

Leakage Current Tests

1. Earth Line Leakage (L-N) – current flowing back through the protective earth conductor of the power cord (class 1 products).
 - 5322A leakage current mode: Differential
2. Touch leakage (L-PE) – leakage current flowing from the chassis (enclosure).
 - 5322A leakage current mode: Passive or Active
 - Also called patient leakage on medical devices
 - Caution!: Active only to be used if UUT does not supply test voltage (VLC only!)
3. Substitute leakage (L-PE) – similar to touch leakage but performed at a lower voltage level (safe voltage ~35 V)
 - 5322A leakage current mode: Substitute

Calibrating Leakage Current Testers

- Using the “mA~” function, the 5322A places resistors between the HI and LO terminals and uses the voltage source from the UUT to simulate the leakage current*
 - 0.1 mA to 30 mA
 - 10 μ A resolution



* Except in Active Leakage Current mode where the 5322A uses its voltage calibrator source (5322A/VLC only)

Calibrating Leakage Current Testers



- New functionality 5322A:
 - Addition of LC (Leakage Current) function line voltage monitor readout.
 - Addresses PAT tester UUT Touch Current calibration test requirement to measure Touch Probe to PE voltage

Multimeter

FLUKE®

Calibration



Meter Function of the 5322A

- Using the “METER” function, the 5322A can measure the voltage and current simultaneously
 - 1100 V AC/DC or 5 kV AC/DC
 - 30 A AC/DC
- It calculates the power, selectable in VA, VAR or W.
- It also displays the phase, selectable as phase angle (in degrees) or power factor

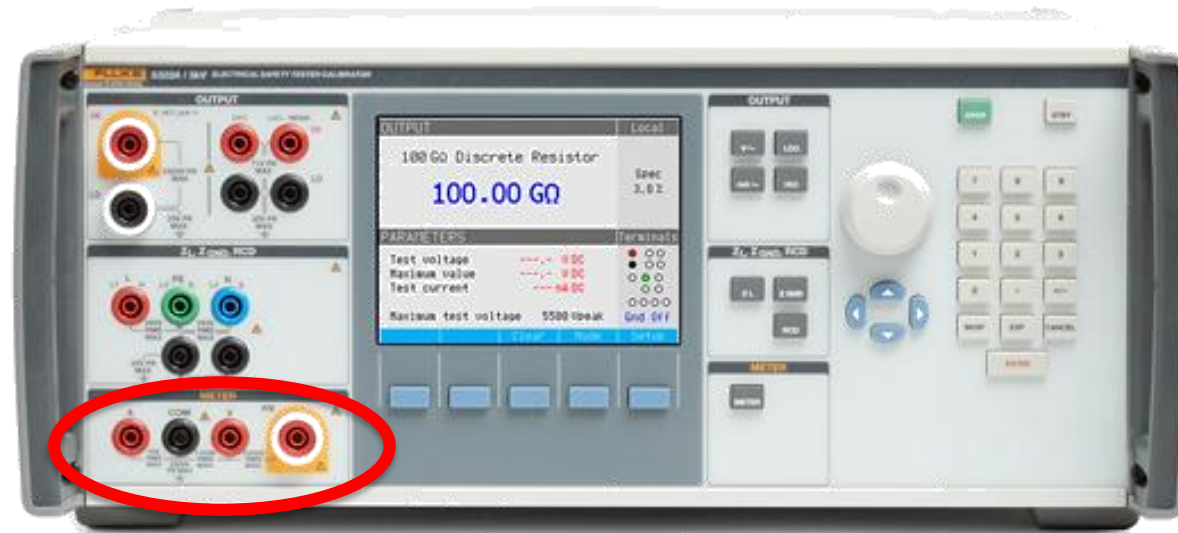

Meter Function of the 5322A – New functionality



- Additional METER voltmeter high voltage range (up to 5 kV rms) and high voltage (HV) input terminal.
 - Direct high voltage measurement up to 5 kV DC and AC rms, without the use of high voltage probes.
 - New 10 kV High Voltage Divider box and optional 40 kV probe
- New METER function voltmeter and ammeter floating inputs, with improved CMRR (common mode rejection ratio).
 - Greatly improve the restricted 5320A common mode range from 25 V to 2.5 kV, eliminating the common mode related limitations and measurement error problems when using the HV Probe/Adapter accessories.



Hipot Testing

FLUKE®

Calibration



Hipot Testing

FLUKE®

Calibration

- A hipot test verifies that the insulation of a product or component is sufficient to protect the operator from electrical shock.
- In a typical hipot test, high voltage is applied between a product's current-carrying conductors and its metallic shielding.
- The resulting current that flows through the insulation, known as leakage current, is monitored by the hipot tester.
- The theory behind the test is that if a deliberate over-application of test voltage does not cause the insulation to break down, the product will be safe to use under normal operating conditions

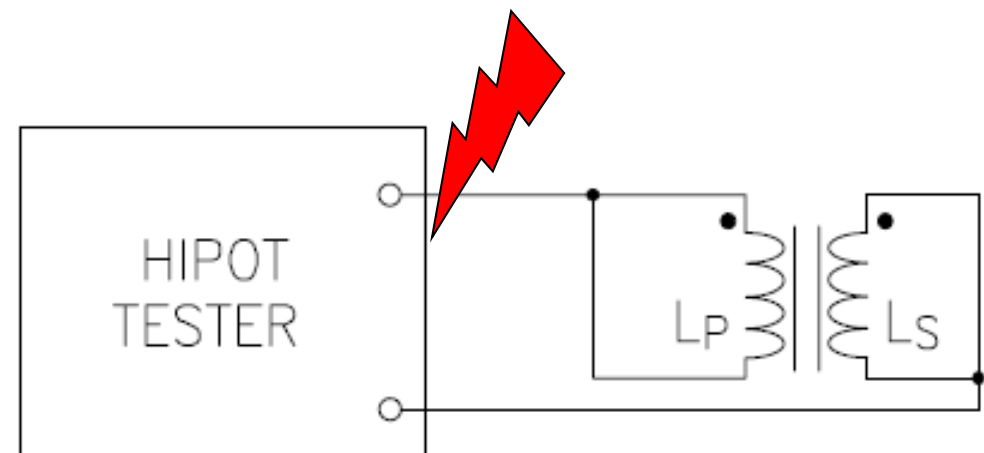

Hipot Testing

FLUKE®

— Calibration

- Now provides complete HiPot tester cal capability:
 - New HiPot LC user-selectable rolling average (n = 1,2, 4, 8, etc...).
 - Addition of Max Hold for HiPot LC current measurement readout.
 - New HiPot voltage DC ripple and AC distortion measurement.
 - New adjustable HiPot voltage threshold for timer.

Hipot Testing / Flash testing

- New Flash Test output voltage and leakage current calibration modes for PAT tester calibration.
 - Overcomes the limitations preventing the 5320A from making measurements of PAT tester UUTs under Class II (3 kV differential, 1.5 kV common mode) Flash test conditions, now fully addressing the PAT tester workload requirements.

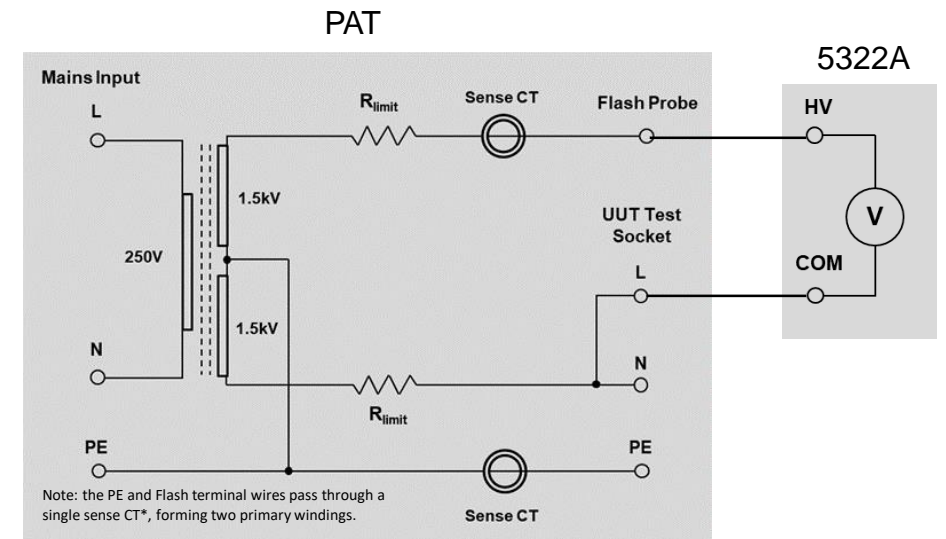
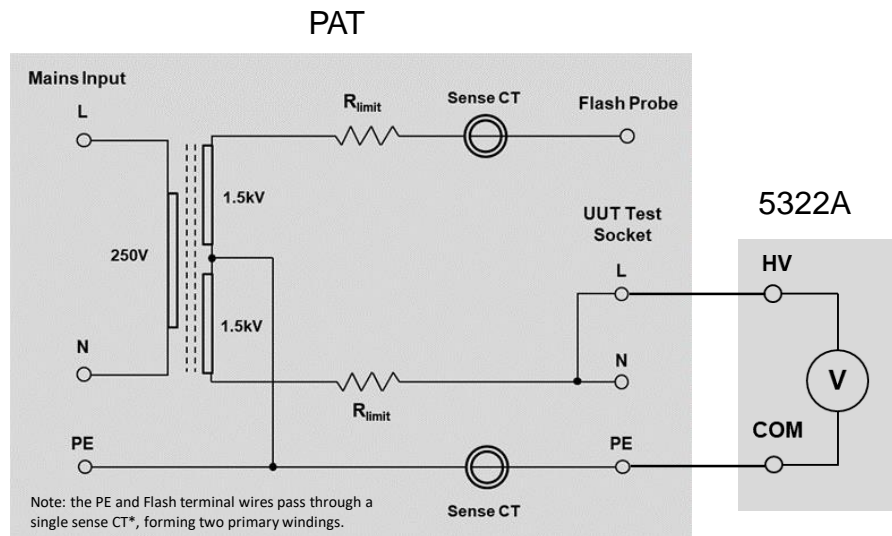

Other improvements

FLUKE®

Calibration

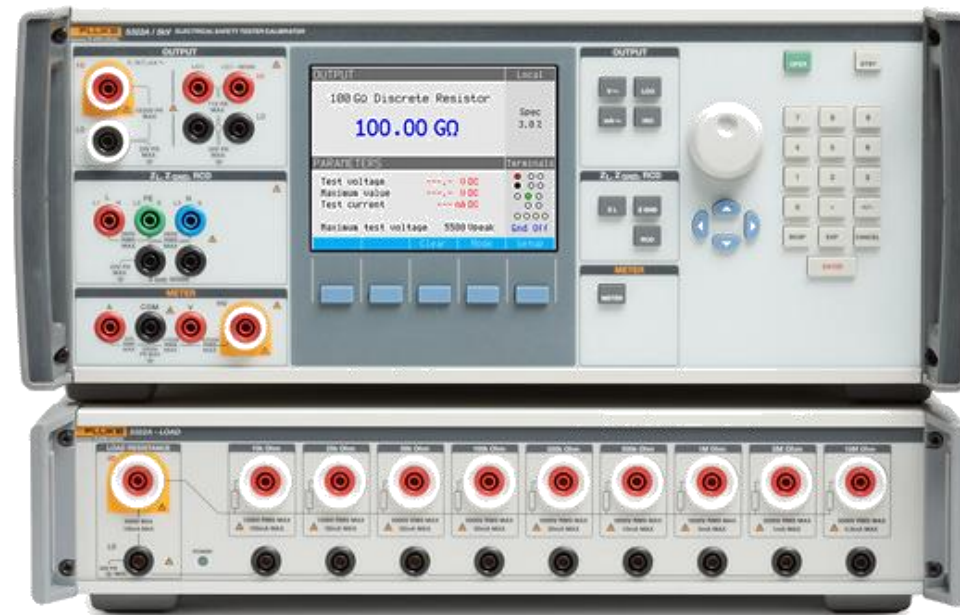

Other improvements built into the 5322A



- VLC Option (**V**oltage - active **L**eakage - loop/line **C**ompensation)
 - Additional DC/AC low voltage output ranges: 30 mV, 300 mV, 3 V and 30 V
 - Increased utility for multimeter, etc, UUT calibration applications, improving workload coverage and ROI potential
- User Interface
 - New x10 and ÷10 softkeys
 - Improved ease of use and operator efficiency when setting decade interval testpoint values

Other improvements built into the 5322A



- Remote Interface

- New USB remote interface, in addition to the existing GPIB (IEEE488)
 - The 5320A RS232 remote interface is replaced by USB.
 - GPIB (IEEE488) interface is still available
 - The command language is SCPI compliant
- The 5322A can emulate the 5320A under GPIB control:
 - The 5322A remote interface command language is compatible with 5320A and the 5322A will 'passively accept' commands for any 5320A features and capabilities not implemented.
 - The IDN? Response is user-selectable to be identical to the 5320A, thus providing emulation capability through a compatible command language.

MET/CAL Support with use of the 5320A FSC

Other improvements built into the 5322A

- Size
 - Calibrator length increased by approximately 50 mm
 - Increased chassis length required to accommodate additional circuitry and larger high voltage components for the 5 kV HVR option, etc.
 - With all the improvements over the 5320A, size matters! 😊



532xA Mains connection – NT vs. IT networks

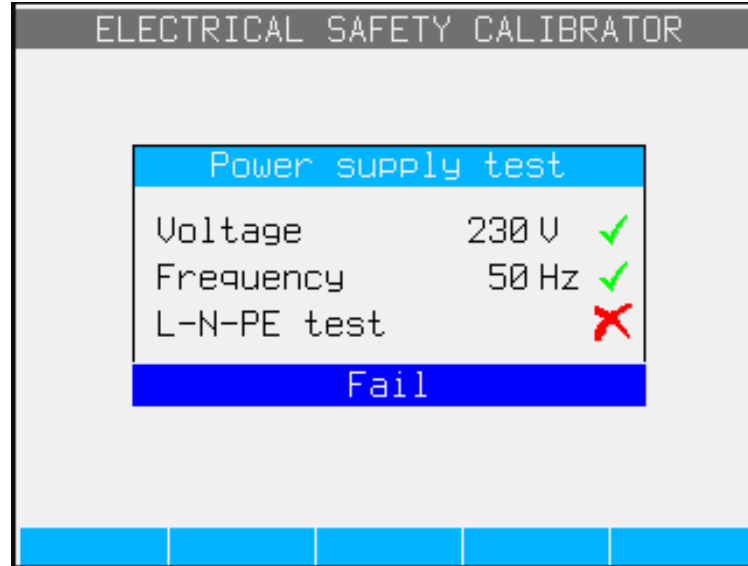
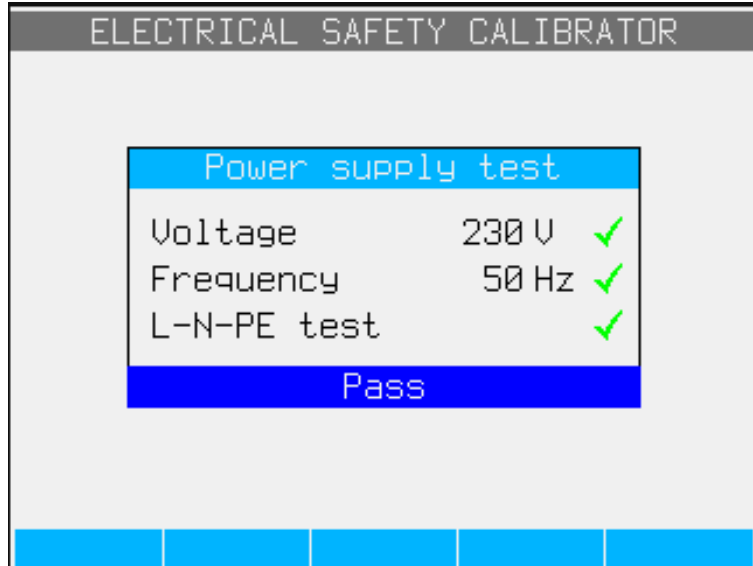

- 532xA needs non-symmetrical electrical mains connection, type NT, with L, N and PE
- On IT networks only through safety transformer – with one phase connected to PE.
 - Applies to Norway and Belgium in selected areas

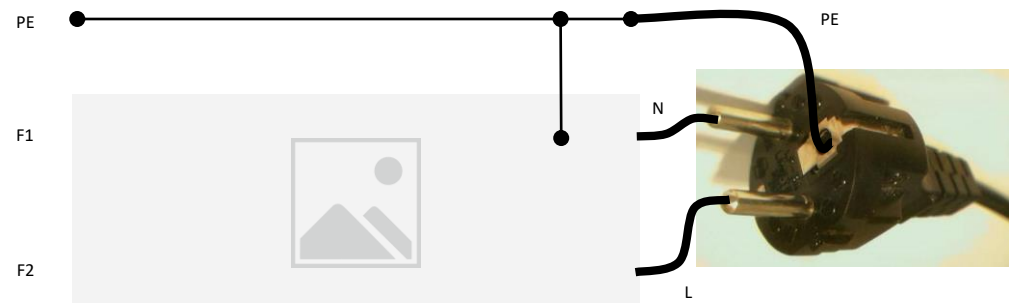

5322A Accessories

FLUKE®

Calibration

- 5322A-LOAD
 - Additional resistance values in High Voltage LOAD Adapter, with increased max voltage rating (5 kV) and new terminal configuration.
 - 9 individual resistance values allow greater range of current values for HiPot leakage current and trip calibration.
 - Values can be easily paralleled to create an even wider range of currents.
 - Values available: 10 kΩ, 25 kΩ, 50 kΩ, 100 kΩ, 250 kΩ, 500 kΩ, 1 MΩ, 5 MΩ, 10 MΩ.



5322A Accessories (included with main unit)

- New 10 kV R-Multiplier box supplied as standard, replacing previous dual-purpose R-Multiplier HV Divider box
 - Extends standard 1.5 kV and optional 5 kV HVR functions to 10 kV.
- New 10 kV HV Divider box supplied as standard, replacing previous dual-purpose R-Multiplier HV Divider box.
 - Extends METER voltmeter range up to 10 kV
 - Better performance up to 10 kV than Fluke 80K-40 40 kV High Voltage Probe option
- Single purpose devices simplify connections, avoiding user issues with the previous dual-purpose design



5322A Accessories (included with main unit)

- New PAT RCD and PAT Load Power Test adapter leads
 - Simplify interconnections, reduce complexity, avoid safety issues, prevent mistakes, and reduce opportunity for error when calibrating PAT testers, improving competitive advantage.
 - PAT testers are apparently straightforward and common workload items, for which calibration practitioners generally do not understand the operating principles of either the UUT or calibrator.



Summary

FLUKE®

Calibration



5322A Summary

- The 5322A replaces the 5320A, with additional features and capabilities:
 - Wider and more complete workload coverage
 - More comprehensive regulatory compliance (mainly China market)
 - Improved robustness and reliability
 - Multi-language UI and built-in Help
- Easier to use individual (10 kV) R-Multiplier and HV Divider boxes



5322A Summary

FLUKE®

Calibration

- The 5322A-LOAD accessory replaces the 5320A-LOAD
 - Higher voltage capability
 - Greater load resistance value (leakage current) choice



5322A Summary

FLUKE®

Calibration

- Functions & Features:
 - Low Resistance Source (2, 3 & 4 wire)
 - High Resistance Source (1.5 kV standard, 5 kV optional)
 - Ground Bond Resistance Source (2 & 4 wire)
 - Line/Loop Impedance Sources
 - Leakage Current Source
 - RCD (RCD, MFT & PAT tester compatible)
 - AC/DC Voltage Calibrator (VLC option only)
 - Multimeter (also provides HiPot Voltage, Leakage/Trip & Timer and PAT Flash)

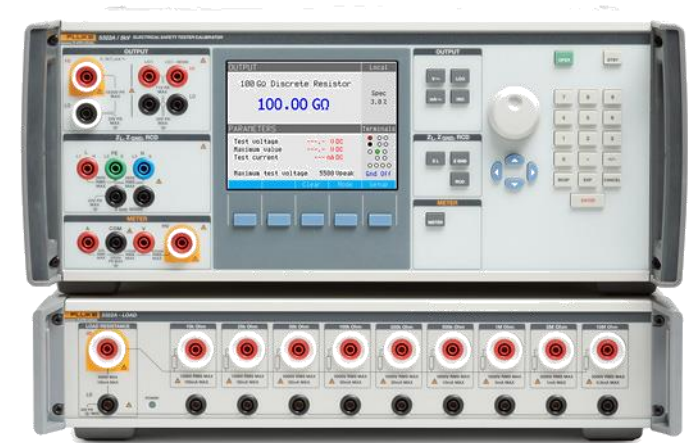

High-Ohms Summary

- Optional choice of existing 1.5 kV (5322A) or new 5 kV High Voltage Resistance (5322A-5) version
- Using the “High Ohms” function, the 5322A sources real resistors, 4½ digits of resolution
 - 10 kΩ to 10 GΩ continuously variable, 100 GΩ fixed (1.5 kV Version, just as the 5320A)
 - 10 kΩ to 100 GΩ continuously variable (5 kV Version)
 - To 10 TΩ/100 TΩ (using the external resistance multiplier)
- During calibration the 5322A simultaneously measures the test voltage and calculates the current from the insulation tester
 - To 1575 V_{peak} (1.5 kV version)
 - To 5500 V_{peak} (5 kV version)

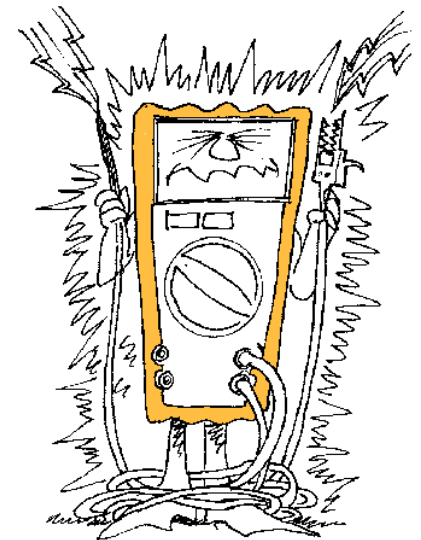

Low-Ohms Summary

- Using the “Lo Ohms” function, the 5322A sources real resistors, 3½ digits of resolution
 - 10 mΩ fixed value
 - 100 mΩ to 10 kΩ
 - 2-, 3- or 4-wire
- During calibration the 5322A simultaneously measures the test current from the earth tester
 - Up to 700 mA (1000 mA for the 10 mΩ fixed value)
 - Check the “Maximum Test Current” value on the display, it differs per selected Ω-value
 - The calibrator will trip to standby if the maximum is exceeded.



Loop and Line Impedance Summary

- Using the “Loop impedance” function (Z_L), the 5322A sources discrete resistors
 - 16 discrete values
 - 20 m Ω to 1700 Ω
- During calibration the 5322A places the known resistor value in series with the loop or line, either in the N or PE path

RCD Summary

FLUKE®

Calibration

- Using the “RCD” function, the 5322A simulates the perfect RCD with a calibrated timer and current meter
 - RCD trip current range
 - 3 mA to 3 A
 - RCD trip time range
 - 10 ms to 5 s
- During calibration the 5322A also measures the waveform type
 - Positive and positive pulse
 - Negative and negative pulse
- Portable RCD testing function of PAT Testers

Ground Bond Summary

- The tester expects a calibrated Low Ohm value which it can measure with a relatively high current
 - Currents can go up to 30 A or 40 A
 - Therefore the Low Resistance Function of the calibrator can not be used
- Using the “ Z_{GND} ” function, the 5322A places high current rated resistors between the N and PE terminals
 - 2 Wire: 20 m Ω – 1700 Ω
 - 4 Wire: 1 m Ω – 1700 Ω
- During calibration the 5322A also measures the test current from the UUT
 - Maximum continuous test current: 30 A
 - Maximum short-term test current: 40 A

Leakage Current Summary

- Using the “mA~” function, the 5322A places resistors between the HI and LO terminals and uses the voltage source from the UUT to simulate the leakage current
 - 0.1 mA to 30 mA
 - 10 μ A resolution
 - 3 or 4 (VLC only) different measurement types



Meter Function Summary

FLUKE®

Calibration

- Using the “METER” function, the 5322A can measure the voltage and current simultaneously
 - 1100 V AC/DC or 5 kV AC/DC
 - 30 A AC/DC
- It calculates the power, selectable in VA, VAR or W.
- It also displays the phase, selectable as phase angle (in degrees) or power factor
- Inputs are now floating to cover Calss II measurements with 1.5 kV common mode



Questions?

FLUKE®

Calibration

QUESTIONS

