

# Network Master™ Series

MT1000A

Network Master Pro

MU100010A

10G Multirate Module



# Redefining Transport Testing

Today's communication networks are becoming more and more sophisticated as leading network operators install new technologies like OTN, MPLS-TP and Ethernet in their metro and backhaul networks. In some cases, operators must also support Fibre Channel links, while still keeping legacy technologies like PDH/DSn and SDH/SONET operational. The Network Master Pro MT1000A redefines the direction of future test platforms by bringing these network test requirements to a portable device, making it the ideal tool for field testing.

The compact, battery-powered and easy-to-use Anritsu MT1000A with 10G Multirate Module MU100010A has everything in a single, handy tester needed to install and maintain communication networks from 1.5 Mbps to 10 Gbps. This portable, compact, lightweight instrument makes network field testing easy. Service engineers can read and interpret data from the tested network directly on the 9-inch color display with easy-to-understand indications and graphical symbols. And the GUI makes it simple to configure and operate the instrument at its full potential. The MT1000A has been designed for easy expandability, reducing initial costs, and facilitating step-by-step customized investment.

### Key Benefits and Features:

- All-in-one transport tester – supports 1.5 Mbps to 10 Gbps
- Easy and intuitive GUI
- Dual port at all rates
- WLAN\*1/Bluetooth/LAN connectivity
- PDF and XML report generation for documenting test results
- Remote operation
- Remote control (scripting)
- Compact, lightweight design for maximum field portability
- High performance in small form factor
- Modular platform ensuring maximum return on investment

### Key Applications:

- Metro and core network installation and maintenance
  - OTN up to OTU2 including mapping of Ethernet, Fibre Channel\*2, SDH/SONET client signals, multistage mapping and FEC (Forward Error Correction)
  - Testing and verification of new OTN functions: ODU0 and ODUflex
- Carrier Class Ethernet installation and troubleshooting
  - Ethernet testing up to 10 GigE including RFC 2544 and Y.1564
  - Ethernet OAM up to 10 GigE
  - MPLS-TP and PBB/PBB-TE up to 10 Gbps
  - IP Channel Statistics up to 10 GigE\*2
  - Frame capture for advanced troubleshooting\*2
- Mobile backhaul installation and verification
  - Synchronous Ethernet Testing up to 10 GigE (G.826x and IEEE 1588 v2)
  - Powerful Storage Area Networking (SAN) testing\*2
  - Fibre Channel up to 10 Gbps
- Quick and easy testing of SDH/SONET and PDH/DSn networks
  - SDH/SONET up to STM-64/OC-192
  - PDH/DSn (E1, E3, E4, DS1, DS3)

\*1: Available for certified countries and regions including USA, Canada, Japan and all EU countries. Please contact Anritsu for updated information.

\*2: Coming soon

## Connector Panel Overview



- 1 Port 1, Tx Bantam (DS1)
- 2 Port 1, Tx BNC (E1, E3, E4, DS3, STM-1e, STS-3)
- 3 Port 1, Rx Bantam (DS1)
- 4 Port 1, Rx BNC (E1, E3, E4, DS3, STM-1e, STS-3)
- 5 Port 2, Tx Bantam (DS1)
- 6 Port 2, Tx BNC (E1, E3, E4, DS3, STM-1e, STS-3)
- 7 Port 2, Rx Bantam (DS1)
- 8 Port 2, Rx BNC (E1, E3, E4, DS3, STM-1e, STS-3)
- 9 Port 1, Tx/Rx RJ48 (E1 balanced)
- 10 Port 2, Tx/Rx RJ48 (E1 balanced)
- 11 Port 1, Tx/Rx SFP+ (OTN, Ethernet, Fibre Channel, SDH/SONET optical)
- 12 Port 2, Tx/Rx SFP+ (OTN, Ethernet, Fibre Channel, SDH/SONET optical)
- 13 Port 1, Tx/Rx RJ45 (Ethernet electrical)
- 14 Port 2, Tx/Rx RJ45 (Ethernet electrical)

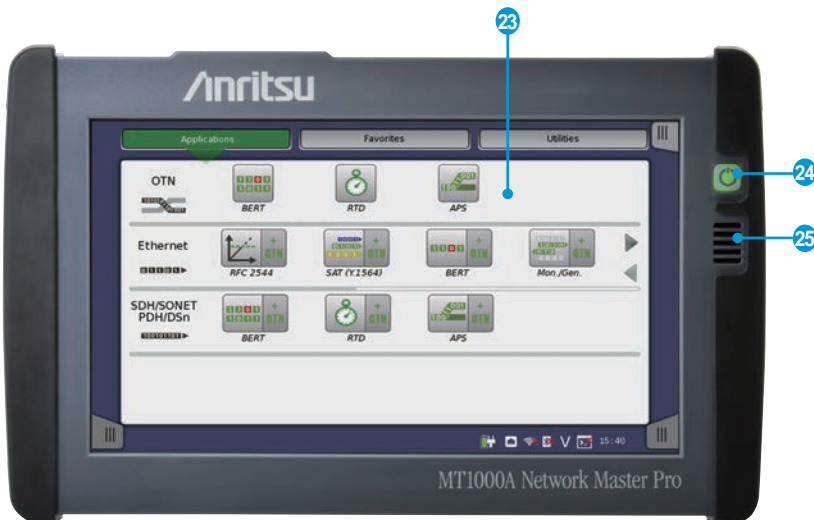

- 15 Audio
- 16 AUX
- 17 Clock Input
- 18 USB Mini-B
- 19 USB A
- 20 USB A
- 21 Ethernet Service Interface
- 22 DC Input (18 Vdc)
- 23 9-inch Active TFT Display and Touch Screen
- 24 Power Switch
- 25 Speaker

# Specifications for MT1000A Network Master Pro Mainframe

User Interface	
Display	9-inch active TFT display (800 × 480 pixels) and touch screen

Service Interfaces	
USB Data Interfaces	MT1000A operates as host: USB 2.0 type A (2 ports) MT1000A operates as device: USB 2.0 type Mini-B (1 port)
Ethernet Interface	Ethernet 10M/100M/1000M, Connector: RJ45
WLAN Interface*	IEEE 802.11 b/g/n
Bluetooth Interface	Bluetooth 2.1 +EDR

\*: Available for certified countries and regions including USA, Canada, Japan and all EU countries. Please contact Anritsu for updated information.

Other Interfaces	
Audio Interface	For connection of optional head set Connector: 3.5-mm diameter jack
AUX Connector	For connection of optional G0325A GPS receiver
Built-in Loudspeaker	Not used
Ext. Clock	For connection of external clock signals: SETS (E1: 2.048 Mbps), BITS (DS1: 1.544 Mbps) or 2.048 MHz TTL signal in accordance with ITU-T G.703 Connector: BNC

Miscellaneous	
Battery	10.8 V rechargeable and replaceable intelligent Li-ion battery Operating time: 4 hours (typ.) Charging time: 3 to 6 hours (typ.) Remaining capacity indication: %
Mains Adapter	Input: 100 V(ac) to 240 V(ac), 50 Hz/60 Hz Output: 18 V(dc), 3.62 A (Max.)
Dimensions and Mass	257 (W) × 164 (H) × 77 (D) mm ≤2.7 kg (including MT1000A, MU100010A and battery)
Environmental	Temperature Operating : 0° to +50°C (non-condensing) Charging: 0° to +40°C (non-condensing) Storage: -30° to +60°C (without Battery, AC adapter) -20° to +50°C (with Battery, AC adapter) Humidity Operating: 85% RH (Max.) Storage and Transportation: 90% RH (Max.)
EMC	EN61326-1, EN61000-3-2
LVD	EN61010-1
Laser Safety*2	IEC 60825-1: 2007 CLASS 1, 21CFR1040.10 and 1040.11*1: MU100010A with optical modules

\*1: Excludes deviations caused by conformance to Laser Notice No. 50 dated June 24, 2007

\*2: Safety measures for laser products

This product complies with optical safety standards in 21CFR1040.10, 1040.11 and IEC 60825-1; the following descriptive labels are affixed to the product.



THIS PRODUCT COMPLIES WITH 21 CFR 1040.10 AND 1040.11 EXCEPT FOR DEVIATIONS PURSUANT TO LASER NOTICE NO. 50, DATED JUNE 24, 2007

# Specifications for MU100010A 10G Multirate Module

## OTN Testing (Options MU100010A-001, MU100010A-051, MU100010A-052, MU100010A-061, MU100010A-062)

OTN Testing	
Test Ports	<ul style="list-style-type: none"> <li>OTU2, OTU1e, OTU2e, OTU1f, OTU2f optical line interfaces: 1 port (MU100010A-051), 2 ports (MU100010A-052)</li> <li>User-selectable optical modules: 1310 nm, 1550 nm</li> <li>OTU1 optical line interfaces: 2 ports (MU100010A-001)</li> <li>User-selectable optical modules: 1310 nm, 1550 nm</li> </ul>
Framing	Complies with ITU-T G.709 [at each OTU rate] FEC: Complies with G.709, RS (255, 239), On/Off
Transmitter Clocks	<ul style="list-style-type: none"> <li>Internal clock accuracy: 4.6 ppm, Clock offset: ±50 ppm (1-ppm steps)</li> <li>Received clock</li> <li>TTL Level external 2 MHz clock</li> <li>SETS (E1: 2.048 Mbps), BITS (DS1: 1.544 Mbps)</li> <li>Signal from optional GPS receiver</li> </ul>
Receive Signal Rate	±50 ppm Frequency deviation indication resolution: ±1 ppm
Scrambling	Complies with ITU-T G.709

### OTN Mappings

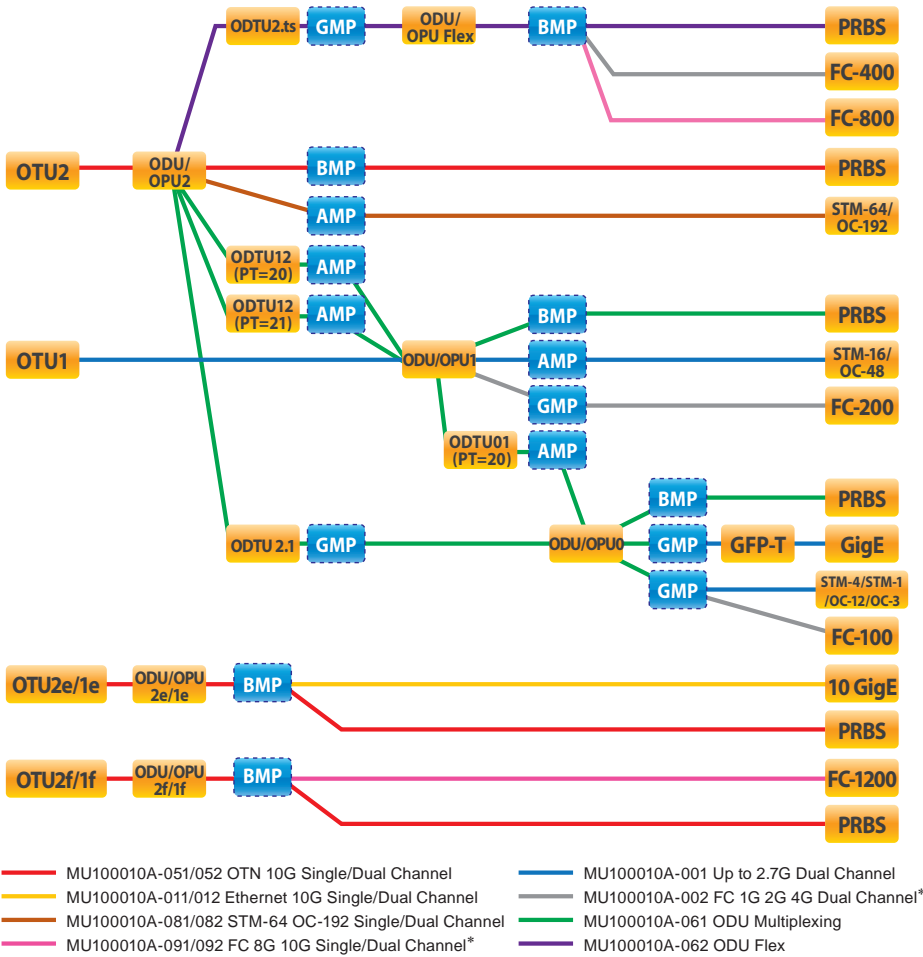

### OTN Alarms

Detected alarms	<ul style="list-style-type: none"> <li>OTU layer: OTU-AIS, LOF, OOF, LOM, OOM, SM-TIM, SM-BIAE, SM-BDI, SM-IAE</li> <li>ODU layer: ODU-AIS, ODU-OCI, ODU-LCK, PM-TIM, PM-BDI</li> <li>ODU multiplexing: ODU-LOFLOM, ODU-OOF</li> <li>OPU layer: PLM, OPU-MSIM, Client-AIS, CSF, LSS</li> <li>TCM: TCMi-TIM, TCMi-BIAE, TCMi-BDI, TCMi-IAE, TCMi-LTC (i = 1 to 6)</li> </ul>
Generated alarms	<ul style="list-style-type: none"> <li>OTU layer: OTU-AIS, OTU-OOF/LOF, OOM/LOM, SM-TIM, SM-BIAE, SM-BDI, SM-IAE</li> <li>ODU layer: ODU-AIS, ODU-OCI, ODU-LCK, PM-TIM, PM-BDI</li> <li>ODU multiplexing: ODU-OOF/LOF, ODU-OOM/LOM</li> <li>OPU layer: Client-AIS, CSF</li> <li>TCM: TCMi-TIM, TCMi-BIAE, TCMi-IAE, TCMi-BDI, TCMi-LTC (i = 1 to 6)</li> </ul>

OTN Errors	<p>Detected errors</p> <ul style="list-style-type: none"> <li>• OTU layer: FAS, MFAS, SM-BEI, SM-BIP8, FEC-Correctable, FEC-Uncorrectable</li> <li>• ODU layer: PM-BIP8, PM-BEI</li> <li>• OPU layer: Pattern error</li> <li>• GMP error: CRC8 error, CRC5 error</li> <li>• GFP-T errors: Core HEC-Correctable errors, Core HEC-Uncorrectable errors, Type HEC-Correctable errors, Type HEC-Uncorrectable errors, CSF signal, CSF sync, Invalid GFP frame, Superblock CRC error</li> <li>• TCM: TCMi-BEI, TCMi-BIP-8 (i = 1 to 6)</li> </ul> <p>Generated errors</p> <ul style="list-style-type: none"> <li>• OTU layer: Bit all, OTU-FAS, MFAS, SM-BIP8, SM-BEI</li> <li>• ODU layer: PM-BIP8, PM-BEI, ODU-FAS</li> <li>• TCMi-BIP8, TCMi-BEI (i = 1 to 6)</li> <li>• Pattern error</li> </ul>
Error Performance	• G.8201/M.2401 analysis of received signal based on detected errors and alarms: BBE, BBER, SES, SESR, UNAV
Justification	<p>Justification (per AMP)</p> <ul style="list-style-type: none"> <li>• Negative (-1)</li> <li>• Positive (+1)</li> <li>• Positive (+2)</li> <li>• Offset (ppm)</li> </ul> <p>Cm(t) (per GMP)</p> <ul style="list-style-type: none"> <li>• Can be set Offset (ppm)</li> </ul>
BER Test Patterns	<p>Pattern generation and detection for bulk test patterns:</p> <ul style="list-style-type: none"> <li>• Test patterns: PRBS 9, PRBS 11, PRBS 15, PRBS 20, PRBS 23, PRBS 29, PRBS 31</li> <li>• PRBS patterns can be inverted.</li> <li>• User-defined patterns (Pattern length: up to 2048 bits, Length step: 8 bits)</li> </ul>
FEC Test	ITU-T O.182 Random error insertion
Overhead	<p>User-editable header bytes</p> <ul style="list-style-type: none"> <li>• OTU layer: FAS, SM, GCC0, RES</li> <li>• ODU layer: PM, FTFL, APS/PCC, GCC1, GCC2, RES, EXP, TCMi (i = 1 to 6)</li> <li>• OPU layer(s): PSI</li> </ul> <p>Capture and display current overhead bytes</p> <p>The following signals are decoded: TTI (SM, PM, TCMi (i = 1 to 6) of high-order, FTFL, PT)</p>
Tributary Signals	<p>Ethernet functionality is supported for Ethernet signals embedded in selected ODU-n (Requires MU100010A-061, MU100010A-062 and MU100010A-001/011/012)</p> <p>SDH/SONET functionality is supported for SDH/SONET signals embedded in selected ODU-n (Requires MU100010A-061 and MU100010A-001/081/082)</p> <p>Fibre Channel functionality is supported for Fibre Channel signals embedded in selected ODU-n (Requires MU100010A-061 and MU100010A-002/091/092) (Coming soon)</p>
Through Mode	<ul style="list-style-type: none"> <li>• Transparent mode</li> <li>• OH overwrite mode</li> </ul> <p>The OTU, ODU and OPU overhead can be changed.</p> <p>The FEC encoder and decoder can be set On/Off in any mode</p>

OTN Results	
Status	<p>Current information on:</p> <ul style="list-style-type: none"> <li>• Alarms and errors on monitored line</li> <li>• Input level indication for optical signals</li> <li>• Frequency</li> <li>• Frequency deviation</li> </ul>
Statistics	<p>User-defined measurement resolution: 1, 2, 5, 10, 15, 30 s, 1, 5, 10, 15, 30 min, 1, 2, 4, 6, 12 h</p> <p>Logged information: Alarms (s), Errors (count or count and ratio)</p>
APS	<p>APS (Automatic Protection Switching) test and analysis</p> <ul style="list-style-type: none"> <li>• APS switching time is measured. A switching time exceeding the user-defined threshold is highlighted.</li> <li>• Start and stop triggers can be selected independently. <ul style="list-style-type: none"> <li>• Trigger events can be selected from the high-order OTU and ODU.</li> </ul> </li> <li>• Switching time, Switching count, Pass/Fail, Minimum, Maximum and Average can be displayed.</li> </ul> <p>APS switching time measurement resolution: 0.1 ms</p>
Round Trip Delay (Propagation Time) Measurement	<p>Resolution: 0.1 <math>\mu</math>s</p> <p>Measured max. time: 10.0 s</p> <p>Interval: 0.5, 1, 2, 5, 10 s</p>

## Ethernet Testing (Options MU100010A-001, MU100010A-011, MU100010A-012)

Ethernet Testing	
Test Ports	<ul style="list-style-type: none"> <li>Optical line interfaces 10 Gbps: 1 port (MU100010A-011) or 2 ports (MU100010A-012) User-selectable optical modules: 850 nm (SR), 1310 nm (LR), 1550 nm (ER) <i>NB: Correct functioning can be guaranteed only with optical modules purchased from Anritsu for the MU100010A.</i></li> <li>Optical line interfaces: 2 ports (MU100010A-001) 1000 Mbps User-selectable optical modules: 850 nm (SX), 1310 nm (LX) and 1550 nm (ZX) or 100 Mbps 1310 nm (FX) <i>NB: Correct functioning can be guaranteed only with optical modules purchased from Anritsu for the MU100010A.</i></li> <li>Electrical line interfaces: 2 ports (MU100010A-001) (in addition to optical ports) RJ45: 10 Mbps, 100 Mbps, 1000 Mbps (unshielded and shielded twisted pair cables, category 5, 5E, 6)</li> </ul>
Test Configurations	<ul style="list-style-type: none"> <li>Monitor/Generate, Pass-through, Reflector</li> </ul>
Encapsulations	<ul style="list-style-type: none"> <li>EtherType II (DIX v.2), IEEE 802.3 with 802.2 (LLC1), IEEE 802.3 with SNAP</li> </ul>

Configuration, Monitor/Generate	
Traffic Generation	<ul style="list-style-type: none"> <li>Variable line rate traffic generation, up to full line rate</li> <li>Line load profile: Constant, Ramp</li> <li>Traffic duration: Continuous, Programmable number of seconds or frames</li> <li>Adjustable frame size: 44 bytes to 16000 bytes</li> <li>Frame sizes: Constant, Stepped, Random</li> <li>Payload profiles: Data, Video, Voice</li> <li>User-defined traffic mix of unicast and broadcast frames</li> <li>Fixed or incremented IP identifier</li> <li>User programmable DSCP/TOS byte</li> <li>Configurable IP and Ethernet source and destination addresses (supports IPv4 and IPv6 addressing) IPv4: Fixed, DHCP, DNS IPv6: Fixed <ul style="list-style-type: none"> <li>Address increment, Decrement and Random generation supported</li> </ul> </li> <li>User programmable UDP/TCP address</li> <li>Automatic TCP connect (user selectable)</li> <li>UDP check sum: Automatic, Fixed (null); TCP check sum: Automatic</li> <li>Generate pause frames, Respond to pause frames</li> <li>Answer incoming ARP, Ping requests (On/Off)</li> </ul>
Stacked VLAN	<ul style="list-style-type: none"> <li>Up to 8 user-settable VLAN tags</li> <li>Parameters per VLAN tag: <ul style="list-style-type: none"> <li>Ether-type 0x8100 (802.1Q), 0x88a8 (802.1ad), 0x9100 or 0x9200</li> <li>User-defined VLAN ID, CFI, VLAN priority <ul style="list-style-type: none"> <li>Address increment, Decrement and Random generation supported</li> </ul> </li> </ul> </li> <li>Only one VLAN level supported at ping, traceroute and RFC 2544 router latency tests</li> </ul>
Multistream	Number of streams: Up to 16 streams per port can be activated
Timing Functionality	<ul style="list-style-type: none"> <li>Timing sources (selectable): Internal, Received clock, 2-MHz signal, SETS (E1: 2.048 Mbps), BITS (DS1: 1.544 Mbps), PTP (IEEE 1588 v2) recovered clock or signal from optional GPS receiver</li> <li>Frequency deviation: <math>\pm 100</math> ppm (1-ppm steps)</li> <li>The frequency deviation of received Ethernet signals can be measured against the internal clock.</li> </ul>
Receiver Settings	<ul style="list-style-type: none"> <li>User-defined expected preamble length: 3 bytes to 15 bytes</li> <li>User-defined IFG lower threshold: 8 bytes to 15 bytes (Ethernet 10 Mbps, 100 Mbps, 1000 Mbps)</li> <li>User-defined Jumbo frame size upper limit: 1519 bytes to 16000 bytes</li> </ul>
Error Generation	FCS, Preamble, Error symbol, IFG for ethernet 10 Mbps, 100 Mbps, 1000 Mbps, Wrong IP check sum, Fragmented IP, Wrong layer 4 check sum, PRBS bit error, BER test sequence error
Alarm Generation	No link, Remote fault, Local fault (Ethernet 10 Gbps)

Results, Monitor/Generate	
Status	<ul style="list-style-type: none"> <li>Link status, Interface type, Jabber detected, Frames present, MPLS/EoMPLS/VLAN, Speed, Full or half duplex, Local clock (Ethernet 1000 Mbps), LFS LF/RF (Ethernet 10 Gbps), Signal present, Bit rate of incoming Ethernet signal, Auto negotiation complete</li> <li>Link partner abilities: Pause capable and Asymmetric pause request (not Ethernet 10 Gbps), Remote fault, Speed/Duplex</li> <li>Indicators for Utilization, Throughput and Errored frames</li> <li>Signal level indication for optical Ethernet interfaces</li> </ul>
Resolution	User-defined resolution for statistical measurements: 1 s, 2 s, 5 s, 10 s, 15 s, 30 s, 1 min, 5 min, 10 min, 15 min, 30 min, 1 h, 2 h, 4 h, 6 h, 12 h
Performance Statistics	Utilization (Max./Min./Avg.), Throughput (Max./Min./Avg.), Frame rate (Max./Min./Avg.)
Frame Statistics	<ul style="list-style-type: none"> <li>Total frames, Total valid frames, Unicast/Multicast/Broadcast frames, Number of pause frames</li> <li>Number of VLAN tagged frames, Max. number of VLAN layers detected, Last received VLAN ID, Last received VLAN priority</li> <li>Number of MPLS frames and MPLS-TP frames. Max. number of MPLS layers detected. Last received MPLS Label, MPLS Priority and MPLS TTL.</li> <li>Number of PBB frames. Last received B/I-tag ID and B/I-tag priority.</li> <li>Total errored frames, Fragmented frames, Number of oversized and undersized (runts) frames, Number of FCS errored frames, Error symbol frames (not Ethernet 10 Gbps)/Code violation frames (Ethernet 10 Gbps), Number of collisions (10 Mbps, 100 Mbps half duplex), Preamble violations, IFG violations (Ethernet 10 Mbps, 100 Mbps, 1000 Mbps), False carrier, 10G LFS LF (local fault), 10G LFS RF (remote fault)</li> </ul>
Burst Statistics	Total frames, Total valid frames, Number of burst, Total frames in bursts, Burst size (Max./Min./Avg.)
Frame Distribution Statistics	<ul style="list-style-type: none"> <li>Total valid/ frames, 64 to 127, 128 to 255, 256 to 511, 512 to 1023, 1024 to 1518 byte frames, Total number of jumbo frames</li> <li>Frame size (Max./Min./Avg.)</li> </ul>
Multistream Statistics	<ul style="list-style-type: none"> <li>Available information per stream: <ul style="list-style-type: none"> <li>Frame loss count/rate, Throughput, Latency, Packet jitter, Frames and bytes received and transmitted</li> </ul> </li> </ul>



Transmit Statistics	Total frames, Total valid frames, Unicast/Multicast/Broadcast frames, FCS errors, Total errors 64 to 127, 128 to 255, 256 to 511, 512 to 1023, 1024 to 1518 byte frames, Total number of jumbo frames Total number of frames (Tx (own port) – Rx (selectable port))
Filters	Up to 8 filter conditions can be defined. Each condition can filter using: IP or MAC source address, IP or MAC destination address, Broadcast address, IEEE OUI value, Encapsulation type, VLAN ID and VLAN tag priority, MPLS, PBB source and destination MAC address, PBB B/I-tag, MPLS-TP source and destination MAC address, TPC/UDP source and destination port, User-defined pattern at defined offset
Adjustable Thresholds	Utilization, Throughput, Errored frames, Collision rate, Unicast frames, Multicast frames, Broadcast frames, Pause frames, Fragmented frames, Undersized frames (runts), Oversized frames, FCS errored frames, IFG violations (Ethernet 10 Mbps, 100 Mbps, 1000 Mbps), Preamble violations, BER test pattern errors, Sequence errors, Diff.Tx-Rx
DHCP	<ul style="list-style-type: none"> <li>• Display source IP address assigned by DHCP</li> <li>• Display current lease expire time</li> <li>• Display IP addresses of primary and secondary DNS server when obtained by DHCP</li> <li>• Gateway setup using DHCP</li> </ul>

BER Test and Service Disruption Measurements	
BER Test	Generation and detection of test patterns, Count of errors in received test pattern, Pattern generation: Unframed (Layer 1), Framed Ethernet (MAC) header (Layer 2), Framed Ethernet (MAC) header with IP header (Layer 3) or Framed Ethernet (MAC) header, Framed with IP header and TCP/UDP header (Layer 4) Detection of sequence errors and loss of sequence synchronization Frame loss count and frame loss seconds Throughput measurement results are calculated for: <ul style="list-style-type: none"> <li>• Utilization layer, Physical layer, Physical layer excluding preamble, Link layer, Network layer and Data layer</li> <li>• Min./Max./Avg. values</li> </ul> Performance (M.2100 type) parameters: ES, SES, ALS, UAT, AVT, EFS Test patterns: PRBS 9, PRBS 11, PRBS 15, PRBS 20, PRBS 23, PRBS 29, PRBS 31, HF test pattern, CRPAT, JTPAT, SPAT, 55 Hex, Fox, 32-bit user programmable User-defined resolution: 1, 2, 5, 10, 15, 30 s, 1, 5, 10, 15, 30 min, 1, 2, 4, 6, 12 h
Error Generation	FCS, Preamble, Error symbol, IFG for Ethernet (10 Mbps, 100 Mbps, 1000 Mbps), Wrong IP check sum, Fragmented IP, Wrong layer 4 check sum, PRBS bit error, BER test sequence error
Alarm Generation	No link, Remote fault
Service Disruption Measurement	Service disruption measurement activated as part of BER test <ul style="list-style-type: none"> <li>• Max./Avg. service disruption time, Resolution: 0.1 <math>\mu</math>s</li> <li>• Number of service disruptions</li> </ul>

RFC 2544	
RFC 2544 Testing	Switch/Router test and Single ended network test modes: <ul style="list-style-type: none"> <li>• Throughput, Frame loss, Latency or Packet jitter, Back-to-back frames (burstability)</li> </ul> End-to-end network test mode (two MU100010A units in Local-remote setup) <ul style="list-style-type: none"> <li>• Throughput, Frame loss, Back-to-back frames (burstability)</li> </ul> Router latency test mode: IP ping based latency test or packet jitter

Service Activation Test (Y.1564)	
Service Activation Test	ITU-T Y.1564 Service Activation Test <ul style="list-style-type: none"> <li>• Up to 8 services per port</li> <li>• Color-aware and Non-color-aware in combinations (IP DSCP or VLAN PCP)</li> <li>• Test modes: One-way (uni- or bi-directional, symmetrical or asymmetrical), Round-trip</li> <li>• Verification against service acceptance criteria: Information rate, Frame transfer delay, Frame delay variation, Frame loss rate, Availability</li> </ul> Optional GPS timing synchronization
Service Configuration Test	<ul style="list-style-type: none"> <li>• Subtests for: Committed information rate, Excess information rate, Traffic policing, Committed burst size, Excess burst size</li> <li>• Step duration: 1 s to 60 s (user programmable)</li> <li>• Number of steps: 1 to 10 (user programmable)</li> <li>• Slope: Rising/Falling</li> <li>• Results: Pass/Fail indication, IR (Min./Avg./Max.), FL (Count/FLR), FTD, FDV (Min./Avg./Max./Current (during measurement))</li> </ul>
Service Performance Test	<ul style="list-style-type: none"> <li>• All services tested simultaneously at CIR</li> <li>• Duration 15 min, 2 h, 24 h, user programmable</li> <li>• Results: Pass/Fail indication, IR (Min./Avg./Max.), FL (Count/FLR), FTD, FDV (Min./Avg./Max./Current (during measurement)), AVAIL (%), Unavail (s)</li> </ul>

Cable Test	
Cable Test	Identifies cable faults like short circuits, or breaks in wire pair, and displays distance from instrument to fault

Ping Test and Traceroute	
Ping Test	For Connectivity and Configuration check <ul style="list-style-type: none"> <li>• Round Trip Time (RTT)</li> <li>• Supports IPv4 and IPv6 addressing</li> <li>• Answer incoming ping requests (On/Off)</li> </ul>
Traceroute	Trace IP route over IP network <ul style="list-style-type: none"> <li>• User-defined Max. number of hops (1 to 255)</li> </ul> Information per hop: Ping time (Min./Max./Avg.), Number of ping timeouts

IP Channel Statistics (Coming soon)	
Statistics	Statistics for up to 230 channels, identified by user-defined combinations of: <ul style="list-style-type: none"> <li>• IPv4, IPv6 or MAC address</li> <li>• VLAN ID or MPLS label</li> <li>• Protocol information</li> <li>• IP next header (protocol)</li> <li>• TCP/UDP ports</li> </ul> Traffic capacity: <ul style="list-style-type: none"> <li>• 10 Mbps, 100 Mbps, 1 Gbps, 10 Gbps, line speeds: 100% line load</li> </ul> Available Information per channel: <ul style="list-style-type: none"> <li>• Frame count/rate, Throughput, Byte count, MPLS frames, IP frame/packet size distribution, IP header bytes, IP fragments, TTL threshold violations, IP packet count/rate, IP bytes, IP throughput, IP header errors, TCP/UDP bytes, TCP/UDP packet count/rate, Throughput, TCP/UDP errored packets, Undersize frames, Oversize frames</li> </ul>

MPLS/MPLS –TP	
Number of MPLS Headers	Up to 8 MPLS headers set by user
Parameters per MPLS Headers	User-defined label, Exp and TTL fields in each MPLS header <ul style="list-style-type: none"> <li>• Address increment, Decrement and Random generation</li> </ul> An EoMPLS (Ethernet over MPLS) or PWE3 (Pseudo wire emulation edge-to-edge) label (RFC 4448 control word) can be added. MPLS can only transport VLAN if EoMPLS activated.
Statistics	<ul style="list-style-type: none"> <li>• Number of labels (Max./Min.)</li> <li>• Number of MPLS-TP frames</li> <li>• Last received MPLS-TP label/priority/TTL</li> </ul>
OAM (MPLS-TP)	ITU-T G.8113.1 comply Supported OAM messages <ul style="list-style-type: none"> <li>• ITU-T Y.1731: CCM, LBM, LBR, LTM, LTR, AIS, LCK, TST, MCC, LMM, LMR, 1DM, DMM, DMR, EXM, EXR, VSM, VSR, SLM, SLR</li> <li>• IEEE 802.1ag: CCM, LBM, LBR, LTM, LTR</li> </ul>

PBB/PBB-TE (Mac-in-Mac MiM)	
Programmable Fields	B-tag, I-tag, MAC destination and source addresses
Results	Number of PBB frames, Last received B-tag VLAN ID, Last received B-tag priority, Last received I-tag priority, Last received I-tag service ID
OAM	Supported OAM messages <ul style="list-style-type: none"> <li>• ITU-T Y.1731: CCM, LBM, LBR, LTM, LTR, AIS, LCK, TST, MCC, LMM, LMR, 1DM, DMM, DMR, EXM, EXR, VSM, VSR, SLM, SLR</li> <li>• IEEE 802.1ag: CCM, LBM, LBR, LTM, LTR</li> </ul>

Ethernet OAM	
OAM Standards Supported	<ul style="list-style-type: none"> <li>• ITU-T Y.1731 (Service layer OAM)</li> <li>• IEEE 802.1ag (Connectivity layer OAM)</li> <li>• IEEE 802.3 (formerly IEEE 802.3ah) (Access link OAM)</li> </ul>
Messages Supported	Generates and receives following OAM messages. Supported OAM messages <ul style="list-style-type: none"> <li>• ITU-T Y.1731: CCM, LBM, LBR, LTM, LTR, AIS, LCK, TST, MCC, LMM, LMR, 1DM, DMM, DMR, EXM, EXR, VSM, VSR, SLM, SLR</li> <li>• IEEE 802.1ag: CCM, LBM, LBR, LTM, LTR</li> <li>• IEEE 802.3ah: Information, Variable request, Variable response, Loopback control</li> </ul>
IEEE 802.3ah Functions	<ul style="list-style-type: none"> <li>• Discovery</li> <li>• Loopback activate</li> </ul>
Statistics	• Number of each message generated/received



Synchronous Ethernet Test	
SyncE (G.826x) Functionality	Specify Quality Level (QL) of transmitted Ethernet signal. Analysis of QL indicated in received Ethernet signal with alarm at missing QL indications. SyncE results: SSM Rx count and rate, SSM Tx count, Indicated QL statistics, SSF seconds ESMC messages captured and exported in Wireshark format.
IEEE 1588 v2 Functionality	Each port of the Ethernet interface can act as a timing master or a timing slave independently Supported modes: Multicast (native PTP), Unicast (G.8265.1). When acting as master in Unicast (G.8265.1) mode, one slave is accepted at a time. If the slave requires 32, 64, or 128 Sync messages per second, IEEE 1588-2008 paragraph 7.7.2.1 specifying 90% confidence interval is not followed. Configurable parameters (per port): Clock identity, Port number, Priority 1, Priority 2, Domain number, Clock class, Slave only mode, Time source, Encapsulation, Announce receipt timeout, Clock accuracy, Clock step mode, Announce interval, Sync interval, Minimum delay request interval and Unicast duration. The UTC offset used when acting as clock master can be specified. IEEE 1588 clock results: Clock state, Announce count, Sync count, Follow-up count, Delay request/response/ follow-up counters, Peer delay request/response/response-follow-up counters Min./Max./Avg. for: Offset, Offset deviation, Offset variance, Mean path delay, Peer mean path delay, Path delay variance, Path delay variation With a GPS signal, the offset from UTC time is calculated. The offset time between the two clocks is always shown. Parent clock results: Identity, Port number Grand-master clock results: Identity, Class, Accuracy, Priority 1, Priority 2, Announced- and Observed offset variance Foreign master clock result (up to 5 clocks per port): Identity, Port number, Announce count Logged IEEE 1588 events: Clock state transitions, State transition events, Faults and Changes in grand-master clock IEEE 1588 messages captured and exported in Wireshark format

Ethernet Frame Capture (Coming soon)	
Capture Buffer Size	1 Mbytes to 128 Mbytes When capture buffer full: Stop or Wrap
Capture Frame Slicing	If activated capture frame is first 64 bytes or 128 bytes of each frame (ignores rest of frame)
Timestamp Resolution	100 ns
Include Tx Frames	On/Off
Capture Trigger	Manual, On error, Field match Trigger position: Top, Middle
Trigger Error	Fragmented frames Oversize frames Undersized frames Undersized and oversized frames FCS errored frames Any type
Trigger Condition Field	Enabled when capture trigger setting is Field match • Offset: 0 to 15999 bytes • Length: 1 bytes to 16 bytes • Value: 16-byte data Max.
Capture Data	Pcap format for display in Wireshark

10G WAN PHY (Coming soon)	
WAN Modes	10 GigE (normal)
Terminology	SONET or SDH
Error Generation	SONET: A1A2, B1, B2, REI-L, B3, REI-P SDH: A1A2, B1, B2, MS-REI, B3, HP-REI
Alarm Generation	SONET: LOF, SEF, TIM-S, AIS-L, RDI-L, AIS-P, LOP-P, TIM-P, PLM-P, UNEQ-P, RDI-P SDH: LOF, OOF, MS-AIS, MS-RDI, MS-TIM, AU-AIS, AU-LOP, HP-PLM, HP-UNEQ, HP-TIM, HP-RDI, LCD
Error Measurement	SONET: A1A2, B1, B2, REI-L, B3, REI-P SDH: A1A2, B1, B2, MS-REI, B3, HP-REI G.826, G.828+G.829 or M.2101.1 (M.2100) error performance parameters are calculated
Alarm Detection	SONET: LOS, LOF, SEF, TIM-S, AIS-L, RDI-L, AIS-P, LOP-P, TIM-P, PLM-P, UNEQ-P, RDI-P, LCD-P, LSS SDH: LOS, LOF, OOF, MS-AIS, MS-RDI, MS-TIM, AU-AIS, AU-LOP, HP-PLM, HP-UNEQ, HP-TIM, HP-RDI, LCD, LSS
Overhead Byte Functionality	Generation of user-defined overhead bytes Capture and display of current overhead bytes
Pointer Operation Monitor	Positive movements, Negative movements, NDF

Reflector	
Reflector Mode	The following parameters are user selectable: • Swap all MAC addresses or one specific MAC address • Swap IP addresses • Swap port numbers on UDP/TCP frames • Force ACK on TCP frames

## Fibre Channel Testing (Options MU100010A-002, MU100010A-091, MU100010A-092) (Coming soon)

Fibre Channel Testing	
Test Ports	<ul style="list-style-type: none"> <li>FC-800 (8GFC), FC-1200 (10GFC) optical line interfaces: 1 port (MU100010A-091), 2 ports (MU100010A-092)</li> <li>User-selectable optical modules: 1310 nm, 1550 nm</li> <li>FC-100 (1GFC), FC-200 (2GFC), FC-400 (4GFC) optical line interfaces: 2 ports (MU100010A-002)</li> <li>User-selectable optical modules: 1310 nm, 1550 nm</li> </ul>
Supported FC Rates	1.0625 Gbps (FC-100/1GFC), 2.125 Gbps (FC-200/2GFC), 4.25 Gbps (FC-400/4GFC), 8.5 Gbps (FC-800/8GFC), 10.52 Gbps (FC-1200/10GFC)
Modes	Terminate, Loopback, Monitor
Topology	Point-to-point
Primitive Sequence Protocol	Count and transmit primitive sequence: LR, LRR, NOS, OLS
Flow Control	Credit based transmitter: On/Off Buffer-to-buffer credit configuration: 1 to 65535, Buffer-to-buffer credit and R_RDY counters, R_RDY injection
Traffic Generation	<ul style="list-style-type: none"> <li>FC-1 (with SOF and EOF frame delimiters and FC-2 frames). Class-3 service frames</li> <li>Traffic shaping: Constant, Ramp, Burst. FC-2 frame header configuration</li> <li>Frame length configuration: 2148 bytes Max.</li> </ul>
Loopback Mode	FC-2 (Layer 2): Swap destination and source IDs
Bit Error Rate (BER) Testing	<ul style="list-style-type: none"> <li>Test modes: Unframed BER test, Layer 1 BER test, Layer 2 BER test</li> <li>Test patterns: PRBS 9, PRBS 11, PRBS 15, PRBS 20, PRBS 23, PRBS 29, PRBS 31, HF test pattern, CSPAT, CJPAT, CRPAT, JTPAT, SPAT, 55 Hex, Fox, 32-bit user programmable</li> <li>Error injection: Bit, CRC</li> <li>Results: Pattern loss seconds, Traffic loss seconds, Bit error count, BER</li> </ul>
Measurements	<ul style="list-style-type: none"> <li>Alarm detection: LOS, Link down, Pattern loss</li> <li>Service disruption measurement: Total service disruption time, Last service disruption time, Min./Max service disruption, Number of service disruptions</li> <li>Traffic statistics: Bandwidth utilization, Data rate, Frame count, Byte count, Frame size distribution, Buffer-to-buffer credit count, R_RDY count, Frame loss count, Round trip delay, Packet jitter, Bit errors, CRC errors, Symbol errors, LR, LRR, NOS, OLS</li> </ul>

**SDH/SONET/PDH/DSn Testing (Options MU100010A-001, MU100010A-081, MU100010A-082)**

<b>SDH and SONET Testing</b>	
Test Ports	<ul style="list-style-type: none"> <li>• STM-64, OC-192 optical interfaces: 1 port (MU100010A-081), 2 ports (MU100010A-082) User-selectable optical modules: 1310 nm, 1550 nm</li> <li>• STM-16/STM-4/STM-1, OC-48/OC-12/OC-3 optical interfaces: 2 ports (MU100010A-001) User-selectable optical modules: 1310 nm, 1550 nm</li> <li>• STM-1e, STS-3 electrical interfaces: 2 ports (MU100010A-001) Connector: BNC</li> </ul>
Framing	SDH: Complies with ITU-T G.707, SONET: Complies with Telcordia GR-253
Transmitter Clocks	<ul style="list-style-type: none"> <li>• Internal clock accuracy: 4.6 ppm, Clock offset: ±50 ppm (1-ppm steps)</li> <li>• Recovered clock</li> <li>• TTL level external 2 MHz clock</li> <li>• SETS (E1: 2.048 Mbps), BITS (DS1: 1.544 Mbps)</li> </ul>
Receive Signal Rate	±50 ppm Frequency deviation indication resolution: ±1 ppm
STM-1e Electrical Attenuation and Impedance Modes	<b>TERMINATE:</b> Up to 12 dB cable attenuation, nominal impedance <b>MONITOR:</b> 20 dB linear attenuation and up to 12 dB cable attenuation, nominal impedance
TCM Frame Format	ITU-T G.783, G.707 Annex D (TCM option 2) and Annex E, POH bytes: N1 (VC-4, VC-3), Z5 (STS-3c, STS-1), N2 (VC-12, VC-11), Z6 (VT-2, VT-1.5) TCM Access Point Identifier (Apid): 15 bytes ASCII sequence, CRC-7
Scrambling	SDH: Complies with ITU-T G.707, SONET: Complies with Telcordia GR-253

**SDH Mappings**

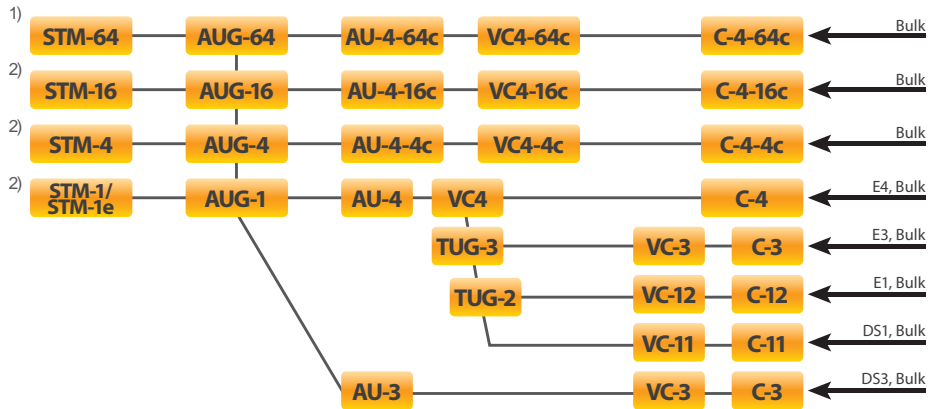

- 1) Requires MU100010A-081 or MU100010A-082
- 2) Requires MU100010A-001

**SONET Mappings**

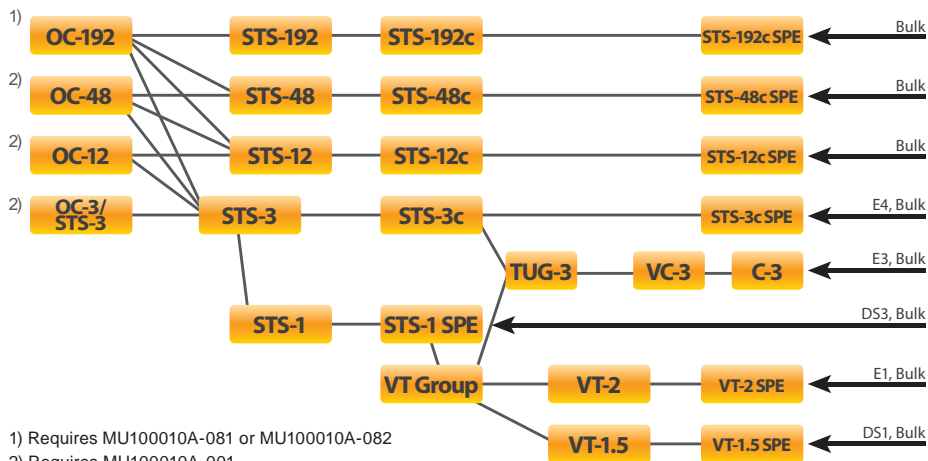

- 1) Requires MU100010A-081 or MU100010A-082
- 2) Requires MU100010A-001

Alarms	<p>Detected and generated alarms</p> <ul style="list-style-type: none"> <li>SDH: LOS, LOF, OOF, MS-AIS, MS-RDI, AU-AIS, AU-LOP, HP-PLM, HP-UNEQ, HP-TIM, HP-RDI, TU-LOM, TU-AIS, TU-LOP, LP-PLM, LP-UNEQ, LP-TIM, LP-RDI, LSS</li> <li>SONET: LOS, LOF, OOF, AIS-L, RDI-L, AIS-P, LOP-P, TIM-P, PLM-P, UNEQ-P, RDI-P, LOM-V, AIS-V, LOP-V, PLM-V, UNEQ-V, RDI-V, TIM-V, LSS</li> <li>TCM: TC-LTC, TC-TIM, TC-UNEQ, TC-AIS, TC-RDI, TC-ODI</li> </ul> <p>Inserted alarms</p> <ul style="list-style-type: none"> <li>Permanent</li> <li>Alternate: 1 to 8000 consecutive alarm frames, 1 to 8000 consecutive normal frames</li> </ul>
Errors	<p>Detected and generated errors</p> <ul style="list-style-type: none"> <li>SDH: A1/A2, B1, B2, MS-REI, B3, HP-REI, V5/B3, LP-REI, Pattern error, ERR trans</li> <li>SONET: A1/A2, B1, B2, REI-L, B3, REI-P, V5/B3, REI-V, Pattern error, ERR trans</li> <li>TCM: TC-IEC, TC-BIP2, TC-REI, TC-OEI</li> </ul> <p>Error insertion</p> <ul style="list-style-type: none"> <li>Manual: 1 to 8000 consecutive errors (excluding Pattern error) 1 to 4000 consecutive errors (for Pattern error)</li> <li>Continuous: <math>10^{-3}</math>, <math>10^{-4}</math>, <math>10^{-5}</math>, <math>10^{-6}</math>, <math>10^{-7}</math>, <math>10^{-8}</math>, <math>10^{-9}</math>, <math>10^{-10}</math> (The available highest rate varies depending on the error item.)</li> <li>Alternate: 1 to 8000 consecutive error frames, 1 to 8000 consecutive normal frames (excluding Pattern error and ERR trans) 1 to 4000 consecutive error bits, 100 to 4000 consecutive normal bits (for Pattern error)</li> </ul>
BER Test Patterns	<p>Pattern generation and detection for O.181 bulk test pattern</p> <ul style="list-style-type: none"> <li>Test patterns supported: PRBS 9, PRBS 11, PRBS 15, PRBS 20, PRBS 23, PRBS 29, PRBS 31</li> <li>PRBS patterns can be inverted.</li> <li>All 0 s, All 1 s, Alternating 1:1, Alternating 1:3, Alternating 1:7, 2 in 8</li> <li>User-defined patterns (Pattern length: up to 2048, Length step: 8-bit)</li> </ul>
Pointers	<ul style="list-style-type: none"> <li>Support pointer events monitoring and generation</li> <li>Pointer test sequences: None, Single alternating, Regular + Double, Regular + Missing, Double alternating</li> <li>Display pointer value of receiver side</li> <li>Graphical display of pointer movements</li> </ul>
Overhead	<ul style="list-style-type: none"> <li>Generation of section/transport and path overhead bytes</li> <li>Display of current section/transport and path overhead bytes</li> </ul> <p>All overhead can be decoded, including decoded J0, J1, J2 byte.</p>
SDH Tributary Signals	<p>DS1 signals embedded in selected VC-11 (Requires MU100010A-001)</p> <p>E1 signals embedded in selected VC-12 (Requires MU100010A-001)</p> <p>E3/DS3 signals embedded in selected VC-3 (Requires MU100010A-001)</p> <p>E4 signals embedded in selected VC-4 (Requires MU100010A-001)</p> <p>The offset of tributary signals (DS1, E1, E3, DS3, E4) can be set at asynchronous mapping</p>
SONET Tributary Signals	<p>DS1 signals embedded in selected VT-1.5 (Requires MU100010A-001)</p> <p>E1 signals embedded in selected VT-2 (Requires MU100010A-001)</p> <p>E3/DS3 signals embedded in selected STS-1 (Requires MU100010A-001)</p> <p>E4 signals embedded in selected STS-3c (Requires MU100010A-001)</p> <p>The offset of tributary signals (DS1,E1, E3, DS3, E4) can be set at asynchronous mapping.</p>
Through Mode	<ul style="list-style-type: none"> <li>Transparent mode</li> <li>OH overwrite mode</li> </ul> <p>Can be changed SOH (SDH), TOH (SONET)</p>

SDH and SONET Results	
Status	<p>Current information on</p> <ul style="list-style-type: none"> <li>Alarms and errors on monitored line</li> <li>Input level indication for optical signals</li> <li>Input level indication for electrical signals</li> <li>Actual bit rate</li> <li>Frequency deviation</li> </ul>
Statistics	<p>User-defined measurement resolution: 1, 2, 5, 10, 15, 30 s, 1, 5, 10, 15, 30 min, 1, 2, 4, 6, 12 h</p> <p>Logged information: Alarms (seconds and ratio), Errors (count or count and ratio), Pointer operations</p>
Error Performance	<p>G.826/G.828/G.829/M.2100 analysis of received signal based on detected errors and alarms:</p> <p>ES, SES, BBE (not M.2100), UNAV</p>
APS	<p>APS (Automatic Protection Switching) test and analysis</p> <ul style="list-style-type: none"> <li>APS switching time is measured. A switching time exceeding the user-defined threshold is highlighted. <ul style="list-style-type: none"> <li>Trigger events (user selectable): <ul style="list-style-type: none"> <li>SDH: SDH alarms and errors; APS switchover</li> <li>SONET: SONET alarms and errors; APS switchover</li> </ul> </li> </ul> </li> <li>Number of switchovers indicated by APS protocol</li> <li>K1/K2 bytes set and displayed</li> </ul> <p>Resolution of APS switching time measurement, SDH</p> <ul style="list-style-type: none"> <li>SDH events excluding VC-12 and VC-11 events, LOS (Loss of Signal): 0.125 ms</li> <li>VC-12 and VC-11 events: 0.5 ms</li> </ul> <p>Resolution of APS switching time measurement, SONET</p> <ul style="list-style-type: none"> <li>SONET events excluding VT-1.5 and VT-2 events, LOS (Loss of Signal): 0.125 ms</li> <li>VT-1.5 and VT-2 events: 0.5 ms</li> </ul>
Round Trip Delay (Propagation Time) Measurement	<p>Resolution: 0.1 <math>\mu</math>s</p> <p>Measured Max. time: 10.0 s</p> <p>Interval: 0.5, 1, 2, 5, 10 s</p>

E1 Testing	
Test Ports	E1 Electrical line interfaces: 2 ports (MU100010A-001) Connector: BNC or RJ 48 (selectable)
General	Complies with ITU-T G.703 for 2048 kbps
Impedance	Supported input impedances • 75Ω (unbalanced), 120Ω (balanced), High (>10 × nominal)
Line Code	HDB3 or AMI
Framing	Unframed or Framed: FAS/nFAS, Transmitter: Sa-bits (non-FAS) user-programmable
Transmitter Clocks	<ul style="list-style-type: none"> <li>• Internal 2.048 Mbps clock accuracy: 4.6 ppm, Clock offset: ±125 ppm (1-ppm steps)</li> <li>• Recovered from receiver</li> <li>• TTL level external 2.048 MHz clock</li> <li>• SETS (E1: 2.048 Mbps), BITS (DS1: 1.544 Mbps)</li> </ul>
Receive Signal Rate	<ul style="list-style-type: none"> <li>• 2048 kbps ±150 ppm</li> <li>• Frequency deviation indication accuracy: ±1 ppm</li> </ul>
Receiver Attenuation and Impedance Modes	<p><u>TERMINATE</u></p> <ul style="list-style-type: none"> <li>• Up to 40 dB cable attenuation, nominal impedance</li> </ul> <p><u>MONITOR</u></p> <ul style="list-style-type: none"> <li>• 20 to 26 dB linear attenuation and up to 6 dB cable attenuation, nominal impedance</li> <li>• 20 to 30 dB linear attenuation, 0 dB cable attenuation, nominal impedance</li> </ul> <p><u>BRIDGED</u></p> <ul style="list-style-type: none"> <li>• Up to 40 dB cable attenuation, high impedance</li> </ul>
Drop and Insert	Supports drop & insert of one or multiple 64 kbps timeslots (TS) within E1
Alarms	Detected and generated alarms: No signal, AIS, No frame, Distant (RDI) alarm, Pattern sync loss, No CAS, MFAS, Distant (RDI) MF alarms
Errors	<p>Detected: FAS/nFAS, CRC4, E-bit, Code, Pattern, Pattern slips, Frame slips</p> <p>Generated: FAS bit, FAS word, CRC-4, E-bit, Code, Pattern, Transparent</p> <p>Error insertion</p> <ul style="list-style-type: none"> <li>• Manual: 1 to 255 consecutive errors (1 to 16 consecutive FAS word errors)</li> <li>• Continuous: 10<sup>-2</sup>, 10<sup>-3</sup>, 10<sup>-4</sup>, 10<sup>-5</sup>, 10<sup>-6</sup>, 10<sup>-7</sup></li> <li>• Provoking of G.821, G.826 or M.2100 events (ES, SES etc.) (FAS, Pattern, CRC-4, E-bit)</li> </ul> <p>Manual slip insertion: Frame slips, Pattern slips</p>
BER Test Patterns	<p>Pattern generation</p> <ul style="list-style-type: none"> <li>• Unframed or Framed: n × 64 kbps in contiguous or non-contiguous channel access</li> </ul> <p>Supported test patterns</p> <ul style="list-style-type: none"> <li>• PRBS 6, PRBS 7, PRBS 9, PRBS 11, PRBS 15, PRBS 20, PRBS 23, QRSS 11, QRSS 20</li> <li>• Fox pattern, Fox (CMA 3000), All 0, All 1, Alternating (1:1), (1:3), (1:7), (3:24)</li> <li>• User-defined up to 32 bits (Length: 1-bit steps)</li> <li>• User-defined up to 2048 bits (Length: 8-bit steps)</li> </ul> <p>All patterns can be inverted, except user-defined</p>
CAS	CAS signaling bits can be set.

E1 Results	
Status	<p>Current Information on</p> <ul style="list-style-type: none"> <li>• Alarms and errors on monitored line</li> <li>• Input level indication</li> <li>• Actual bit rate</li> <li>• Frequency deviation</li> <li>• FAS/non-FAS and CAS bits</li> <li>• Traffic overview: Busy/Idle indication from all 31 channels</li> </ul>
Statistics	<p>User-defined measurement resolution: 1, 2, 5, 10, 15, 30 s, 1, 5, 10, 15, 30 min, 1, 2, 4, 6, 12 h</p> <p>Logged information: Alarms (seconds and ratio), Errors (count or count and ratio), Frequency deviation information</p>
Error Performance	<p>G.821, G.826 or M.2100 analysis of PRBS in received signal, or based on CRC-4, E-bit or FAS: ES, SES, BBE (G.826), UAT, EFS, AT % or count.</p> <p>Error performance evaluation for total measurement:</p> <ul style="list-style-type: none"> <li>• HR% for user-defined error performance parameter or programmable OK and not-OK limits for FAS, Pattern, CRC-4 or E-bit count or ratio</li> </ul>
APS	<p>APS switching time is measured. A switching time exceeding the user-defined threshold is highlighted.</p> <p>Number of switchovers.</p> <p>Trigger events (User selectable): 2 Mbps alarms (LOF or AIS)</p> <p>Resolution of APS switching time measurement: LOF and AIS: 0.25 ms</p>
Round Trip Delay (Propagation Time) Measurement	<p>Resolution: 1 μs</p> <p>Measured Max. time: 10.0 s</p> <p>Interval: 0.5, 1, 2, 5, 10 s</p>

DS1 Testing	
Test Ports	DS1 electrical line interfaces: 2 ports (MU100010A-001) Connector: Bantam
General	Complies with ANSI T1.102 for 1544 kbps.
Impedance	100Ω or high (10 × nominal; Receiver only) and DSX MON 100Ω ±1%
Line Code	B8ZS, AMI
Framing	Unframed or Framed, Framed: SF, ESF, J-ESF (J1)
Transmitter Clocks	<ul style="list-style-type: none"> <li>• Internal 1.544 Mbps clock accuracy: 4.6 ppm, Clock offset: ±125 ppm (1-ppm steps)</li> <li>• Recovered from receiver</li> <li>• TTL level external 2.048 MHz clock</li> <li>• SETS (E1: 2.048 Mbps), BITS (DS1: 1.544 Mbps)</li> </ul>
Line Build Out	0, -7.5, -15, -22.5 dB 0 to 133 ft, 133 to 266 ft, 266 to 399 ft, 399 to 533 ft, 533 to 655 ft
Receive Signal Rate	1544 kbps ±150 ppm Frequency deviation indication resolution: ±1 ppm
Receiver Sensitivity	<p><u>DS1 Short Haul</u></p> <ul style="list-style-type: none"> <li>• 15 dB linear attenuation, 0 dB cable attenuation, nominal impedance</li> </ul> <p><u>TERMINATE</u></p> <ul style="list-style-type: none"> <li>• Up to 36 dB cable attenuation, nominal impedance</li> </ul> <p><u>DSX MONITOR</u></p> <ul style="list-style-type: none"> <li>• 15 to 25 dB linear attenuation, nominal impedance</li> </ul> <p><u>BRIDGE</u></p> <ul style="list-style-type: none"> <li>• Up to 36 dB cable attenuation, high impedance</li> </ul>
Drop and Insert	Drop & Insert of one or multiple 56 kbps or 64 kbps timeslots (TS) within DS1
Alarms	Generated and detected: LOS, OOF, AIS (Blue), RAI (Yellow), LSS
Errors	Generated or detected: Pattern, F-bit, S-bit, Pattern slips, BPV (Code), CRC-6, EXZ Error insertion <ul style="list-style-type: none"> <li>• Manual: 1 to 255 consecutive errors</li> <li>• Continuous: 10<sup>-2</sup>, 10<sup>-3</sup>, 10<sup>-4</sup>, 10<sup>-5</sup>, 10<sup>-6</sup>, 10<sup>-7</sup></li> <li>• For performance: ES, SES</li> </ul>
BER Test Patterns	Supported test patterns <ul style="list-style-type: none"> <li>• PRBS 9, PRBS 11, PRBS 15, PRBS 20, PRBS 23, PRBS 29, PRBS 31, QRSS 20</li> <li>• All 0, All 1, Alternating (1:1), (1:3), (1:7), (3:24), Fox pattern, Fox (CMA 3000)</li> <li>• User-defined up to 32 bits (Length: 1-bit steps)</li> <li>• User-defined up to 2048 bits (Length: 8-bit steps)</li> </ul> All patterns can be inverted, except User-defind
Loopback Codes	Supported loopback codes: A_LLA, A_LLD, A_PLA, A_PLD, A_ULB, A_NLA, A_USR, A_ACS, A_DCS, A_AN1, A_DN1, A_AN2, A_DN2, A_100K, A_USE_INBAND (User-defined FDL/in-band code) Insertion: On/Off

DS1 Results	
Status	Current Information on <ul style="list-style-type: none"> <li>• Alarms and errors on monitored line</li> <li>• Input level indication</li> <li>• Actual bit rate</li> <li>• Frequency deviation</li> <li>• Contents of one time slot</li> <li>• Framing and CAS bits</li> </ul>
Statistics	User-defined measurement resolution: 1, 2, 5, 10, 15, 30 s, 1, 5, 10, 15, 30 min, 1, 2, 4, 6, 12 h Logged information: Alarms (seconds and ratio), Errors (count or count and ratio), Frequency deviation information
Error Performance	G.821, G826, or M.2100 analysis of PRBS in received signal, or based on detected errors: ES, SES, ALS, UAT, AVT, EFS, BBE (G.826)
APS	APS switching time is measured. A switching time exceeding the user-defined threshold is highlighted. Number of switchovers. Trigger events (User selectable): 1.5 Mbps alarms (OOF, AIS) APS switching time measurement resolution: No frame, AIS: 0.25 ms
Round Trip Delay (Propagation Time) Measurement	Resolution: 1 μs Measured Max. time: 10.0 s Interval: 0.5, 1, 2, 5, 10 s



E3 Testing	
Test Ports	E3 electrical line interfaces: 2 ports (MU100010A-001) Connector: BNC
General	Complies with ITU-T G.703 for 34368 kbps
Impedance	75Ω
Line Code	HDB3
Framing	Unframed or Framed: Complies with ITU-T G.751 for E3 signals
Transmitter Clocks	<ul style="list-style-type: none"> <li>Internal clock accuracy: 4.6 ppm, Clock offset: ±125 ppm (1-ppm steps)</li> <li>Recovered from receiver</li> <li>TTL level external 2.048 MHz clock</li> <li>SETS (E1: 2.048 Mbps), BITS (DS1: 1.544 Mbps)</li> </ul>
Receive Signal Rate	34368 kbps ±150 ppm Frequency deviation indication resolution: ±1 ppm
Attenuation and Impedance Modes	<p><u>TERMINATE</u></p> <ul style="list-style-type: none"> <li>Up to 12 dB cable attenuation, nominal impedance</li> </ul> <p><u>MONITOR</u></p> <ul style="list-style-type: none"> <li>20 dB linear attenuation and up to 12 dB cable attenuation, nominal impedance</li> <li>20 to 30 dB linear attenuation, 0 dB cable attenuation, nominal impedance</li> </ul>
Alarms	Detected and generated alarms: No signal, AIS, No frame, RDI, Pattern sync loss
Errors	Detected and generated errors: Frame, Code, Pattern, Pattern slip Error insertion <ul style="list-style-type: none"> <li>Manual: 1 to 255 consecutive errors</li> <li>Continuous: 10<sup>-2</sup>, 10<sup>-3</sup>, 10<sup>-4</sup>, 10<sup>-5</sup>, 10<sup>-6</sup>, 10<sup>-7</sup></li> <li>For performance: ES, SES</li> </ul>
BER Test Patterns	Pattern Generation and Detection, Supported test patterns <ul style="list-style-type: none"> <li>PRBS 9, PRBS 11, PRBS 15, PRBS 20, PRBS 23</li> <li>Fox pattern, Fox (CMA 3000), All 0, All 1, Alternating 1:1, Alternating 1:3, Alternating 1:7, Alternating 3:24</li> <li>User-defined up to 32 bits (Length: 1-bit steps)</li> <li>User-defined up to 2048 bits (Length: 8-bit steps)</li> </ul> All patterns can be inverted, except user-defined

E3 Results	
Status	Current Information on <ul style="list-style-type: none"> <li>Alarms and errors on monitored line</li> <li>Input level indication</li> <li>Actual bit rate</li> <li>Frequency deviation</li> </ul>
Statistics	User-defined measurement resolution: 1, 2, 5, 10, 15, 30 s, 1, 5, 10, 15, 30 min, 1, 2, 4, 6, 12 h Logged information: Alarms (seconds and ratio), Errors (count or count and ratio), Frequency deviation information
Error Performance	G.826/M.2100 analysis of received signal, or based on detected errors ES, SES, ALS, UAT, AVT, EFS, BBE (G.826)
Round Trip Delay (Propagation Time) Measurement	Resolution: 1 μs Measured Max. time: 10.0 s Interval: 0.5, 1, 2, 5, 10 s

DS3 Testing	
Test Ports	DS3 electrical line interfaces: 2 ports (MU100010A-001) Connector: BNC
General	Complies with ANSI for 44736 kbps
Impedance	75Ω
Line Code	B3ZS
Framing	Unframed or Framed, Framed: C-bit parity, M13 in accordance with ANSI T1.107
Transmitter Clocks	<ul style="list-style-type: none"> <li>Internal clock accuracy: 4.6 ppm, Clock offset: ±125 ppm (1-ppm steps)</li> <li>Recovered from receiver</li> <li>TTL level external 2.048 MHz clock</li> <li>SETS (E1: 2.048 Mbps), BITS (DS1: 1.544 Mbps)</li> </ul>
Line Build Out	0 ft, 225 ft
Receive Signal Rate	44736 kbps ±150 ppm Frequency deviation indication resolution: ±1 ppm
Attenuation and Impedance Modes	<p><u>TERMINATE</u></p> <ul style="list-style-type: none"> <li>Up to 12 dB cable attenuation, nominal impedance</li> </ul> <p><u>MONITOR</u></p> <ul style="list-style-type: none"> <li>20 dB linear attenuation and up to 12 dB cable attenuation, nominal impedance</li> <li>20 to 30 dB linear attenuation, 0 dB cable attenuation, nominal impedance</li> </ul>
Alarms	Detected and generated alarms: LOS, LOF, AIS (Blue), RAI (Yellow), DS3 idle, LSS
Errors	Detected and generated errors: Pattern, C-bit, F-bit, P-bit, Code (BPV), FEBE (detect only), EXZ (detect only) Error insertion <ul style="list-style-type: none"> <li>Manual: 1 to 255 consecutive errors</li> <li>Continuous: 10<sup>-2</sup>, 10<sup>-3</sup>, 10<sup>-4</sup>, 10<sup>-5</sup>, 10<sup>-6</sup>, 10<sup>-7</sup></li> </ul>
BER Test Patterns	Pattern generation and detection, Supported test patterns <ul style="list-style-type: none"> <li>PRBS 9, PRBS 11, PRBS 15, PRBS 20, PRBS 23, PRBS 29, PRBS 31, QRSS 20</li> <li>Fox pattern, Fox (CMA 3000), All 0, All 1, Alternating 1:1, Alternating 1:3, Alternating 1:7, Alternating 3:24</li> <li>User-defined up to 32 bits (Length: 1-bit steps)</li> <li>User-defined up to 2048 bits (Length: 8-bit steps)</li> </ul> All patterns can be inverted, except user-defined
Loopback Codes	Supports FEAC and C-bits loopback (ANSI T1.404 & T1.107a)

DS3 Results	
Status	Current information on <ul style="list-style-type: none"> <li>• Alarms and errors on monitored line</li> <li>• Input level indication</li> <li>• Actual bit rate</li> <li>• Frequency deviation</li> </ul>
Statistics	User-defined measurement resolution: 1, 2, 5, 10, 15, 30 s, 1, 5, 10, 15, 30 min, 1, 2, 4, 6, 12 h Logged information: Alarms (seconds and ratio), Errors (count or count and ratio), Frequency deviation
Error Performance	G.826/M.2100 analysis of received signal, or based on detected errors ES, SES, ALS, UAT, AVT, EFS, BBE (G.826)
Round Trip Delay (Propagation Time) Measurement	Resolution: 1 $\mu$ s Measured Max. time: 10.0 s Interval: 0.5, 1, 2, 5, 10 s

E4 Testing	
Test Ports	E4 electrical line interfaces: 2 ports (MU100010A-001) Connector: BNC
General	Complies with ITU-T G.703 for 139264 kbps interfaces
Impedance	75 $\Omega$
Line Code	CMI
Framing	Unframed or Framed: Complies with ITU-T G.751 for E4 signals
Transmitter Clocks	<ul style="list-style-type: none"> <li>• Internal clock accuracy: 4.6 ppm, Clock offset: <math>\pm</math>125 ppm (1-ppm steps)</li> <li>• Recovered from receiver</li> <li>• TTL level external 2.048 MHz clock</li> <li>• SETS (E1: 2.048 Mbps), BITS (DS1: 1.544 Mbps)</li> </ul>
Receive Signal Rate	139264 kbps $\pm$ 150 ppm Frequency deviation indication resolution: $\pm$ 1 ppm
Attenuation and Impedance Modes	<u>TERMINATE</u> <ul style="list-style-type: none"> <li>• Up to 12 dB cable attenuation, nominal impedance</li> </ul> <u>MONITOR</u> <ul style="list-style-type: none"> <li>• 20 dB linear attenuation and up to 12 dB cable attenuation, nominal impedance</li> </ul>
Alarms	Detected and generated alarms: No signal, AIS, No frame, RDI, Pattern sync loss
Errors	Detected and generated errors: Frame, Pattern error, Pattern slips Error insertion <ul style="list-style-type: none"> <li>• Manual: 1 to 255 consecutive errors</li> <li>• Continuous: <math>10^{-2}</math>, <math>10^{-3}</math>, <math>10^{-4}</math>, <math>10^{-5}</math>, <math>10^{-6}</math>, <math>10^{-7}</math></li> <li>• For performance: ES, SES</li> </ul>
BER Test Patterns	Pattern generation and detection, Supported test patterns <ul style="list-style-type: none"> <li>• PRBS 9, PRBS 11, PRBS 15, PRBS 20, PRBS 23, PRBS 29, PRBS 31, QRSS 20</li> <li>• All 0, All 1, Alternating 1:1, Alternating 1:3, Alternating 1:7, Alternating 3:24</li> <li>• User-defined up to 32 bits (Length: 1-bit steps)</li> <li>• User-defined up to 2048 bits (Length: 8-bit steps)</li> </ul> All patterns can be inverted, except user-defined

E4 Results	
Status	Current information on <ul style="list-style-type: none"> <li>• Alarms and errors on monitored line</li> <li>• Input level indication</li> <li>• Actual bit rate</li> <li>• Frequency deviation</li> </ul>
Statistics	User-defined measurement resolution: 1, 2, 5, 10, 15, 30 s, 1, 5, 10, 15, 30 min, 1, 2, 4, 6, 12 h Logged information: Alarms (seconds and ratio), Errors (count or count and ratio), Frequency deviation
Error Performance	G.826/M.2100 analysis of received signal, or based on detected errors ES, SES, ALS, UAT, AVT, EFS, BBE (G.826)
Round Trip Delay (Propagation Time) Measurement	Resolution: 1 $\mu$ s Measured Max. time: 10.0 s Interval: 0.5, 1, 2, 5, 10 s

# Ordering Information

Please specify the model/order number, name and quantity when ordering.  
The names listed in the chart below are Order Names. The actual name of the item may differ from the Order Name.

## 1. Mainframe

Model/Order No.	Name
MT1000A	Network Master Pro

One of the following power line cords is supplied with the MT1000A

Model/Order No.	Name
J1565A	Line Cord USA
J1594A	Line Cord Japan
J1566A	Line Cord Europe
J1567A	Line Cord UK
J1568A	Line Cord Australia
J1596A	Line Cord Korea

The following items are supplied with the MT1000A

Model/Order No.	Name
Z1746A	Stylus
G0309A	AC Adapter
Z1817A	Utilities ROM
G0310A	Li-ion Battery
W3681AE	MT1000A/MU100010A Quick Reference Guide
B0690A	Softbag
Z1747A	Carrying Strap
Z1748A	Handle
B0692A	ESD Box (for optical modules)

## 2. Module

Model/Order No.	Name
MU100010A	10G Multirate Module

## 3. Options\*1

Model/Order No.	Name
MU100010A-001*2	Up to 2.7G Dual Channel
MU100010A-011*3	Ethernet 10G Single Channel
MU100010A-012*3	Ethernet 10G Dual Channel
MU100010A-051*4	OTN 10G Single Channel
MU100010A-052*4	OTN 10G Dual Channel
MU100010A-061*5	ODU Multiplexing
MU100010A-062*6	ODU Flex
MU100010A-081*7	STM-64 OC-192 Single Channel
MU100010A-082*7	STM-64 OC-192 Dual Channel
MU100010A-002	FC 1G 2G 4G Dual Channel*
MU100010A-091*8	FC 8G 10G Single Channel*
MU100010A-092*8	FC 8G 10G Dual Channel*
MT1000A-003*9	Connectivity for WLAN/ <i>Bluetooth</i>

\*: Coming soon

\*1: This option can be retrofitted.

The Model/Order No. of retrofit options is "-3\*\*".

Example

As a retrofit, MU100010A-001 Up to 2.7G Dual Channel becomes MU100010A-301 Up to 2.7G Dual Channel Retrofit.

In addition, specify one of the following media along with the required option.

Z1849A: Retrofit Options in DVD-ROM

Z1850A: Retrofit Options in USB Stick

Z1851A: Retrofit Options via E-mail

\*2: Includes SDH up to STM-16, SONET up to OC-48, PDH (E1, E3, E4), DSn (DS1, DS3), OTN (OTU1) and Ethernet (10 Mbps, 100 Mbps, 1 Gbps)

\*3: MU100010A-011, MU100010A-012: Only one of these options can be installed.

\*4: MU100010A-051, MU100010A-052: Only one of these options can be installed.

\*5: MU100010A-061: Requires that at least one of the following options is installed: MU100010A-001, MU100010A-051, MU100010A-052

\*6: MU100010A-062: Requires that at least one of the following options is installed: MU100010A-001, MU100010A-051, MU100010A-052

\*7: MU100010A-081, MU100010A-082: Only one of these options can be installed.

\*8: MU100010A-091, MU100010A-092: Only one of these options can be installed.

\*9: Available for certified countries and regions including USA, Canada, Japan and all EU countries.

Please contact Anritsu for updated information.

## 4. Optional Accessories

Model/Order No.	Name
G0311A	1G 850 nm SX SFP
G0312A	1G 1310 nm LX SFP
G0313A	1G 1550 nm ZX SFP
G0332A	100M FX 1310 nm MM SFP
G0333A	10G SR/SW 850 nm SFP+
G0315A	10G LR/LW 1310 nm SFP+
G0316A	10G ER/EW 1550 nm 40 km SFP+
G0318A	10G ZR/ZW 1550 nm 80 km SFP+
G0319A	Up to 2.7G 1310 nm 15 km SFP
G0320A	Up to 2.7G 1310 nm 40 km SFP
G0321A	Up to 2.7G 1550 nm 80 km SFP
G0328A	1G/2G/4G FC 850 nm SFP*
G0322A	1G/2G/4G FC 1310 nm SFP*
G0323A	1G/2G/4G FC 1550 nm SFP*
G0329A	10G LR 1310 nm SFP+
B0691A	Hard Case
G0324A	Battery Charger
J1569A	Car 12 Vdc Adapter
J1570A	Head Set
G0325A	GPS Receiver
W3682AE	MT1000A/MU100010A Operation Manual
Z1821A	Utilities in USB Stick
J1571A	Optical Cable SM LC/PC to SC/PC 3 m
J1575A	Optical Cable SM LC/PC to FC/PC 3 m
J1579A	Optical Cable SM LC/PC to LC/PC 3 m
J1581A	Optical Cable MM LC/PC to LC/PC 3 m
J1583A	Optical Attenuator 10 dB LC/PC to LC/PC
J1584A	RJ45 Cable 3 m
J1585A	RJ48 to Crocodile Clips Cable 3 m
J1586A	RJ48 to Crocodile Clips Cable 20 dB ATT 3 m
J1588A	BNC Cable 2.5 m
J1589A	BNC to 1.6/5.6 Cable 2.5 m
J1591A	RJ48 to Two 3-pin Banana Plug Cable 2.5 m
J1597A	RJ48 Balanced PDH Cable Crossed 3 m
J1598A	Bantam Cable 3 m

\*: Coming soon

## 5. Maintenance Service

Model/Order No.	Name
MT1000A-ES210	2 Years Extended Warranty Service
MT1000A-ES310	3 Years Extended Warranty Service
MU100010A-ES210	2 Years Extended Warranty Service
MU100010A-ES310	3 Years Extended Warranty Service

● **United States**

**Anritsu Company**

1155 East Collins Blvd., Suite 100, Richardson,  
TX 75081, U.S.A.  
Toll Free: 1-800-267-4878  
Phone: +1-972-644-1777  
Fax: +1-972-671-1877

● **Canada**

**Anritsu Electronics Ltd.**

700 Silver Seven Road, Suite 120, Kanata,  
Ontario K2V 1C3, Canada  
Phone: +1-613-591-2003  
Fax: +1-613-591-1006

● **Brazil**

**Anritsu Eletrônica Ltda.**

Praça Amadeu Amaral, 27 - 1 Andar  
01327-010 - Bela Vista - São Paulo - SP - Brazil  
Phone: +55-11-3283-2511  
Fax: +55-11-3288-6940

● **Mexico**

**Anritsu Company, S.A. de C.V.**

Av. Ejército Nacional No. 579 Piso 9, Col. Granada  
11520 México, D.F., México  
Phone: +52-55-1101-2370  
Fax: +52-55-5254-3147

● **United Kingdom**

**Anritsu EMEA Ltd.**

200 Capability Green, Luton, Bedfordshire, LU1 3LU, U.K.  
Phone: +44-1582-433200  
Fax: +44-1582-731303

● **France**

**Anritsu S.A.**

12 avenue du Québec, Bâtiment Iris 1- Silic 612,  
91140 VILLEBON SUR YVETTE, France  
Phone: +33-1-60-92-15-50  
Fax: +33-1-64-46-10-65

● **Germany**

**Anritsu GmbH**

Nemetschek Haus, Konrad-Zuse-Platz 1  
81829 München, Germany  
Phone: +49-89-442308-0  
Fax: +49-89-442308-55

● **Italy**

**Anritsu S.r.l.**

Via Elio Vittorini 129, 00144 Roma, Italy  
Phone: +39-6-509-9711  
Fax: +39-6-502-2425

● **Sweden**

**Anritsu AB**

Kistagången 20B, 164 40 KISTA, Sweden  
Phone: +46-8-534-707-00  
Fax: +46-8-534-707-30

● **Finland**

**Anritsu AB**

Teknobulevardi 3-5, FI-01530 VANTAA, Finland  
Phone: +358-20-741-8100  
Fax: +358-20-741-8111

● **Denmark**

**Anritsu A/S**

Kay Fiskers Plads 9, 2300 Copenhagen S, Denmark  
Phone: +45-7211-2200  
Fax: +45-7211-2210

● **Russia**

**Anritsu EMEA Ltd.**

**Representation Office in Russia**

Tverskaya str. 16/2, bld. 1, 7th floor.

Russia, 125009, Moscow  
Phone: +7-495-363-1694  
Fax: +7-495-935-8962

● **United Arab Emirates**

**Anritsu EMEA Ltd.**

**Dubai Liaison Office**

P O Box 500413 - Dubai Internet City  
Al Thuraya Building, Tower 1, Suit 701, 7th Floor  
Dubai, United Arab Emirates  
Phone: +971-4-3670352  
Fax: +971-4-3688460

● **India**

**Anritsu India Private Limited**

2nd & 3rd Floor, #837/1, Binnamangla 1st Stage,  
Indiranagar, 100ft Road, Bangalore - 560038, India  
Phone: +91-80-4058-1300  
Fax: +91-80-4058-1301

● **Singapore**

**Anritsu Pte. Ltd.**

11 Chang Charn Road, #04-01, Shriro House  
Singapore 159640  
Phone: +65-6282-2400  
Fax: +65-6282-2533

● **P.R. China (Shanghai)**

**Anritsu (China) Co., Ltd.**

Room 2701-2705, Tower A,  
New Caohejing International Business Center  
No. 391 Gui Ping Road Shanghai, 200233, P.R. China  
Phone: +86-21-6237-0898  
Fax: +86-21-6237-0899

● **P.R. China (Hong Kong)**

**Anritsu Company Ltd.**

Unit 1006-7, 10/F., Greenfield Tower, Concordia Plaza,  
No. 1 Science Museum Road, Tsim Sha Tsui East,  
Kowloon, Hong Kong, P.R. China  
Phone: +852-2301-4980  
Fax: +852-2301-3545

● **Japan**

**Anritsu Corporation**

8-5, Tamura-cho, Atsugi-shi, Kanagawa, 243-0016 Japan  
Phone: +81-46-296-1221  
Fax: +81-46-296-1238

● **Korea**

**Anritsu Corporation, Ltd.**

5FL, 235 Pangyoyeok-ro, Bundang-gu, Seongnam-si,  
Gyeonggi-do, 463-400 Korea  
Phone: +82-31-696-7750  
Fax: +82-31-696-7751

● **Australia**

**Anritsu Pty. Ltd.**

Unit 21/270 Ferntree Gully Road, Notting Hill,  
Victoria 3168, Australia  
Phone: +61-3-9558-8177  
Fax: +61-3-9558-8255

● **Taiwan**

**Anritsu Company Inc.**

7F, No. 316, Sec. 1, NeiHu Rd., Taipei 114, Taiwan  
Phone: +886-2-8751-1816  
Fax: +886-2-8751-1817

Please Contact: