

2657A

High Power System SourceMeter® Instrument



- Source or sink up to 180W of DC power ($\pm 3000\text{V}@20\text{mA}$, $\pm 1500\text{V}@120\text{mA}$)
- Fully TSP® compliant for easy system integration with other Series 2600A System SourceMeter models
- 10fA resolution for pico-amp level measurements even at 3kV
- Dual 22-bit precision ADCs and dual 18-bit digitizers for high accuracy and high speed transient capture
- Full power at DC or pulse at any duty cycle
- Combines a precision power supply, current source, DMM, arbitrary waveform generator, V or I pulse generator, electronic 18-bit load, and trigger controller – all in one instrument
- Includes TSP® Express characterization software, LabVIEW® driver and Keithley's Test Script Builder software development environment

TYPICAL APPLICATIONS

- Power semiconductor device characterization and testing
- Characterization of GaN, SiC, and other compound materials and devices
- Breakdown and leakage testing to 3kV
- Characterization of sub-millisecond transients

The high power Model 2657A is the newest addition to the Series 2600A family of System SourceMeter instruments. It is designed specifically for characterizing and testing high voltage electronics to help you improve productivity in applications in R&D, reliability, and production test environments. It is useful for characterizing power semiconductors, such as diodes, MOSFETs and IGBTs, as well as other components and materials in applications in which high voltage, fast response, and precise measurements of voltage and current are required.

The Model 2657A, like every Series 2600A SourceMeter instrument, offers a highly flexible, four-quadrant voltage and current source/load coupled with precision voltage and current meters. It can be used as:

- Semiconductor characterization instrument
- V or I waveform generator
- V or I pulse generator
- Precision power supply with V and I readback
- True current source
- Digital multimeter (DCV, DCI, ohms, and power with 5½-digit resolution)
- Precision electronic load

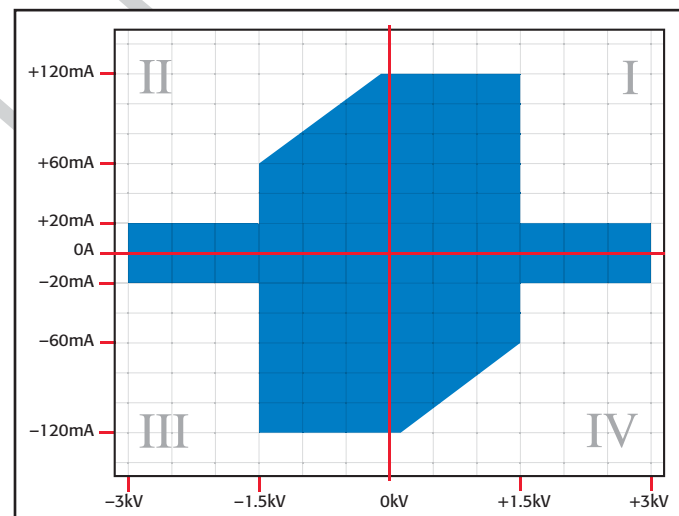

The Model 2657A can source or sink up to 3000V @ 20mA or 1500V @ 120mA.

1.888.KEITHLEY (U.S. only)

www.keithley.com

KEITHLEY

A GREATER MEASURE OF CONFIDENCE

2657A

Ordering Information

2657A High Power System SourceMeter Instrument

8010 High Power Device Test Fixture

Accessories Supplied

7709-308A Digital I/O and Interlock Connector

CA-180-3A TSP-Link/Ethernet Cable

Documentation CD

Software tools and drivers CD

ACCESSORIES AVAILABLE

2657A-LIM-3	Low Interconnect Module
2657A-PM-200	200V Protection Module
4299-6	Fixed Rack Mount Kit
CA-553-xC	High Voltage Triax to SHV Cable (1, 2, 3m)
CA-554-xC	High Voltage Triax to Triax Cable (0.5, 1, 2, 3m)
CA-571-3A	Bulkhead HV Triax to Unterminated Cable
CS-1613	High Voltage Triax Feedthrough Connector

ACCESSORIES SUPPLIED WITH THE 8010

CA-558-1	25-pin D-sub Interlock Cable for 26xxA
CA-560-x	4mm Black and Red Banana Cables, 8 in.
CA-562-x	6mm Black and Red Banana Cables, 10 in.
CA-563	BNC to Banana Cable, 9.5 in.
CA-568-120A	Safety Earth Ground Cable
8010-DTB	Device Test Board with TO-247 Socket
8010-CTB	Customizable Test Board

ACCESSORIES AVAILABLE FOR THE 8010

8010-DTB-220	Device Test Board with TO-220 Socket (1kV)
--------------	--

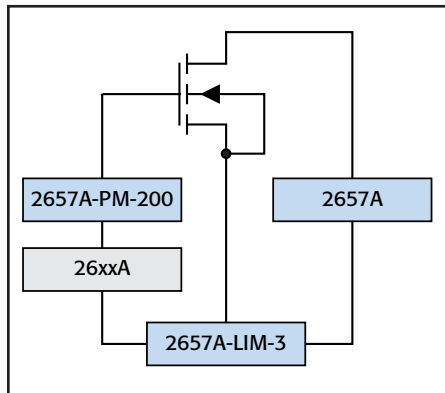

The Model 2657A can be combined with other Series 2600A and Model 4200-SCS SMUs to support multi-terminal test capability. The Models 2657A-PM-200 Protection Module and 2657A-LIM-3 Low Interconnect Module make it easier to connect multiple instruments to a probe station safely (not required for connecting to the Model 8010 High Power Device Test Fixture).

High Power System SourceMeter Instrument

Two Measurement Modes: Digitizing or Integrating

Precisely characterize transient and steady-state behavior, including rapidly changing thermal effects, with the two measurement modes in the Model 2657A. Each mode is defined by its independent analog-to-digital (A/D) converters.

The Digitizing Measurement mode provides speeds up to $1\mu\text{s}$ per sample. The dual 18-bit digitizers allow you to capture voltage and current transients simultaneously. In the Integrating Measurement mode, the dual 22-bit integrating analog to digital converters allow more precise measurement of voltage and current. Two A/D converters are used with each measurement mode, one for current and the other for voltage, that run simultaneously for accurate source readback that does not sacrifice test throughput.

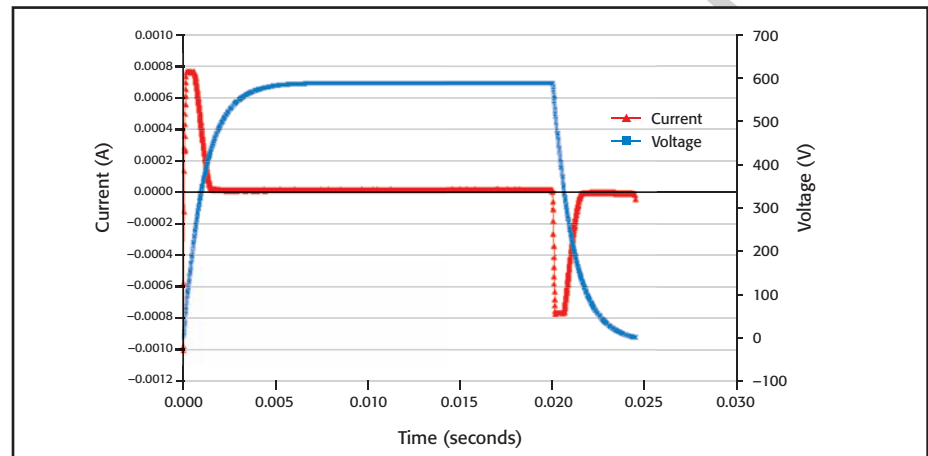

The dual high speed A/D converters will sample as fast as $1\mu\text{s}$ per point, enabling full simultaneous characterization of both voltage and current.

Expansion Capabilities

Through TSP-Link[®] technology, the Model 2657A can be linked with other Series 2600A instruments to form a larger integrated system with up to 32 nodes. Precision timing and tight channel synchronization are guaranteed with built-in 500ns trigger controllers. The fully isolated, independent channels of the SourceMeter instruments make true SMU-per-pin testing possible.

High Power Device Test Fixture

The Model 8010 High Power Device Test Fixture provides safe and easy connections for testing packaged high power devices at up to 3000V or 100A. The Model 8010 provides connections for a high voltage SourceMeter instrument (Model 2657A), one or two high current SourceMeter instruments (Model 2651A), and three low power SourceMeter instruments (other Series 2600A or Model 4200-SCS SMUs). This allows devices with two terminals (diodes) or three terminals (transistors) or even four or five terminals to be characterized safely and accurately. The Model 8010 has full interlock capability for up to six SourceMeter instruments. The Model 8010 has integrated protection circuits that protect the low voltage SourceMeter instruments from high voltages the Model 2657A can output should a device fault occur. The Model 8010 includes both a high current (100A) and a high voltage (3000V) test socket. Various replacement test socket modules are available, including TO-247, TO-220, axial lead, and a blank socket module that allows building a custom socket.

1.888.KEITHLEY (U.S. only)

www.keithley.com

KEITHLEY

A GREATER MEASURE OF CONFIDENCE

2657A

High Power System SourceMeter Instrument

Standard Capabilities of Series 2600A Instruments

Each Model 2657A includes all the features and capabilities provided in the other Series 2600A instruments:

- Flexibility for use as either a bench-top I-V characterization tool or as a building block component of multiple channel I-V test systems
- TSP Express software to perform common I-V tests quickly and easily without programming or installing software
- ACS Basic Edition software for semiconductor component characterization (optional). ACS Basic Edition now features a "Trace" mode for generating a suite of characteristic curves.
- Keithley's Test Script Processor (TSP) technology supports creating and running custom user test scripts for high speed test automation, as well as creating programming sequences that allow the instrument to operate asynchronously without direct PC control.
- Parallel test execution and precision timing when multiple Series 2600A instruments are connected together in a system
- LXI Class C compliance
- 14 digital I/O lines for direct connection to a probe station, component handler, or other automation tools
- USB port for extra data and test program storage via USB memory device



Model 8010 High Power Device Test Fixture

Model 2657A Condensed Specifications

VOLTAGE ACCURACY SPECIFICATIONS ¹

Range	Source			Display Resolution	Measure	
	Programming Resolution	Accuracy \pm (% rdg + volts)	Noise (Vpp) ³ 0.1 Hz to 10 Hz		Integrating ADC Accuracy ² \pm (% rdg + volts)	High Speed ADC Accuracy ⁴ \pm (% rdg + volts)
200.000 V	5 mV	0.03% + 50 mV	5 mV	1 mV	0.025% + 50 mV	0.05% + 100 mV
500.000 V	10 mV	0.03% + 125 mV	10 mV	1 mV	0.025% + 100 mV	0.05% + 200 mV
1500.00 V	40 mV	0.03% + 375 mV	20 mV	10 mV	0.025% + 300 mV	0.05% + 600 mV
3000.00 V	80 mV	0.03% + 750 mV	40 mV	10 mV	0.025% + 600 mV	0.05% + 1.2 V

CURRENT ACCURACY SPECIFICATIONS ⁵

Range	Source			Display Resolution	Measure	
	Programming Resolution	Accuracy \pm (% rdg + amps)	Noise (Ipp) ³ 0.1 Hz to 10 Hz		Integrating ADC Accuracy ² \pm (% rdg + amps)	High Speed ADC Accuracy ⁴ \pm (% rdg + amps)
1.00000 nA	30 fA	0.1% +2E-12+VoE-15	800 fA	10 fA	0.1% +6E-13+VoE-15	0.2% +6E-13+VoE-15
10.0000 nA	300 fA	0.1% +5E-12+VoE-15	2 pA	100 fA	0.1% +5E-12+VoE-15	0.2% +5E-12+VoE-15
100.000 nA	3 pA	0.1% +6E-11+VoE-13	5 pA	1 pA	0.1% +6E-11+VoE-13	0.2% +6E-11+VoE-13
1.00000 μ A	30 pA	0.03% + 700 pA	25 pA	10 pA	0.025% + 400 pA	0.08% + 800 nA
10.0000 μ A	300 pA	0.03% + 5 nA	60 pA	100 pA	0.025% + 1.5 nA	0.08% + 3 nA
100.000 μ A	3 nA	0.03% + 60 nA	3 nA	1 nA	0.02% + 25 nA	0.05% + 50 nA
1.00000 mA	30 nA	0.03% + 300 nA	6 nA	10 nA	0.02% + 200 nA	0.05% + 400 nA
2.00000 mA	60 nA	0.03% + 1.2 μ A	200 nA	10 nA	0.02% + 500 nA	0.05% + 1 μ A
20.0000 mA	600 nA	0.03% + 12 μ A	400 nA	100 nA	0.02% + 5 μ A	0.05% + 10 μ A
120.000 mA	3 μ A	0.03% + 36 μ A	720 nA	1 μ A	0.02% + 24 μ A	0.05% + 50 μ A

1. For temperatures 0° to 18°C and 28° to 50°C, accuracy is degraded by $\pm(0.15 \times \text{accuracy specification})/^{\circ}\text{C}$.
2. Derate accuracy specification for NPLC setting <1 by increasing error term. Add appropriate typical percent of range term for resistive loads using the table below.

NPLC Setting	200 V and 500V Ranges	1500V and 3000 V Ranges	100 nA Range	1 μ A to 120 mA Ranges
0.1	0.01%	0.01%	0.01%	0.01%
0.01	0.08%	0.07%	0.1%	0.05%
0.001	0.8%	0.6%	1%	0.5%
3. Supplemental characteristic.
4. 18-bit ADC. Average of 1000 samples taken at 1 μ s intervals.
5. For temperatures 0° to 18°C and 28° to 50°C, accuracy is degraded by $\pm(0.35 \times \text{accuracy specification})/^{\circ}\text{C}$.



Model 2657A rear panel.

2657A

High Power System SourceMeter Instrument

TRIGGERING AND SYNCHRONIZATION SPECIFICATIONS

TRIGGERING: Trigger in to Trigger Out: 0.5 μ s, typical.

SYNCHRONIZATION: Single- or multi-node synchronized source change: <0.5 μ s, typical.

PROGRAMMING

TEST SCRIPT BUILDER: Integrated development environment for building, running, and managing TSP scripts.

TSP EXPRESS (Embedded): Tool that allows users to perform common I-V tests quickly and easily without programming or installing software.

SOFTWARE INTERFACE: TSP Express (Embedded), Direct GPIB/VISA, Read/Write with VB, VC/C++, VC#, LabVIEW, TestPoint, LabWindows/CVI, etc.

SYSTEM EXPANSION

The TSP-Link expansion interface allows TSP-enabled instruments to trigger and communicate with each other. See figure below:

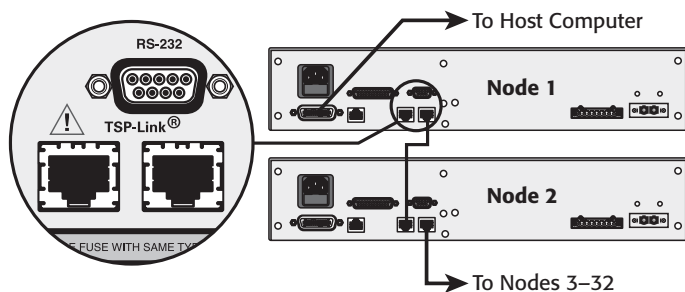

GENERAL

USB: USB 2.1 Host Controller, supports external data storage.

CONTACT CHECK: 1ms minimum measurement time; 5% basic accuracy.

PC INTERFACE: IEEE-488.1 and .2; LXI Class C Ethernet; RS-232.

DIGITAL I/O INTERFACE: Input/Output Pins: 14 open drain I/O bits. 5.25V max.

POWER SUPPLY: 100V to 250VAC, 50Hz–60Hz (auto sensing), 550VA max

COOLING: Forced air. Side and top intake and rear exhaust.

EMC: Conforms to European Union EMC Directive.

SAFETY: ETL listed (PENDING). Conforms to European Union Low Voltage Directive.

WARRANTY: 1 year.

DIMENSIONS: 89mm high \times 435mm wide \times 549mm deep (3.5 in \times 17.1 in \times 21.6 in). Bench Configuration (with handle and feet): 104mm high \times 483mm wide \times 620mm deep (4.1 in \times 19 in \times 24.4 in).

WEIGHT: 9.98kg (22 lbs).

ENVIRONMENT: For indoor use only.

CALIBRATION PERIOD: One year.

Specifications are subject to change without notice.
All Keithley trademarks and trade names are the property of Keithley Instruments, Inc.
All other trademarks and trade names are the property of their respective companies.



A GREATER MEASURE OF CONFIDENCE

KEITHLEY INSTRUMENTS, INC. ■ 2975 AURORA RD. ■ CLEVELAND, OH 44139-1891 ■ 440-248-0400 ■ Fax: 440-248-6168 ■ 1-888-KEITHLEY ■ www.keithley.com

BELGIUM
Sint-Pieters-Leeuw
Ph: 02-3630040
Fax: 02-3630064
info@keithley.nl
www.keithley.nl

CHINA
Beijing
Ph: 86-10-8447-5556
Fax: 86-10-8275-5018
china@keithley.com
www.keithley.com.cn

FRANCE
Saint-Aubin
Ph: 01-64532020
Fax: 01-60117726
info@keithley.fr
www.keithley.fr

GERMANY
Germering
Ph: 089-84930740
Fax: 089-84930734
info@keithley.de
www.keithley.de

INDIA
Bangalore
Ph: 080-26771071, -72, -73
Fax: 080-26771076
support_india@keithley.com
www.keithley.com

ITALY
Peschiera Borromeo (MI)
Ph: 02-5538421
Fax: 02-55384228
info@keithley.it
www.keithley.it

JAPAN
Tokyo
Ph: 81-3-5733-7555
Fax: 81-3-5733-7556
info.jp@keithley.com
www.keithley.jp

KOREA
Seoul
Ph: 82-2-574-7778
Fax: 82-2-574-7838
keithley@keithley.co.kr
www.keithley.co.kr

MALAYSIA
Penang
Ph: 60-4-643-9679
Fax: 60-4-643-3794
sea@keithley.com
www.keithley.com

NETHERLANDS
Gorinchem
Ph: 0183-635333
Fax: 0183-630821
info@keithley.nl
www.keithley.nl

SINGAPORE
Singapore
Ph: 65-6747-2077
Fax: 65-6747-2091
sea@keithley.com
www.keithley.com

SWITZERLAND
Zürich
Ph: 044-8219444
Fax: 044-8203081
info@keithley.ch
www.keithley.ch

TAIWAN
Hsinchu
Ph: 886-3-572-9077
Fax: 886-3-572-9031
info_tw@keithley.com
www.keithley.com.tw

UNITED KINGDOM
Theale
Ph: 0118-9297500
Fax: 0118-9297519
info@keithley.co.uk
www.keithley.co.uk

